



WORKPLACE ACTIVITIES





Reading Text



HANDOUT: Efficient Reading: Dislocations (3 pages)
Skill Builders: Key Words & Phrases, Skimming, Scanning

IN THE WORKPLACE: People read text for different purposes. Whatever the reason for reading, being able to quickly and accurately find and understand the information you need makes reading both more pleasant and more efficient.

Refer to the excerpt from the text **How to Treat a Dislocation** to complete the tasks and locate answers to the questions.

Being able to predict content from titles and sub-titles in a document is an effective strategy to make it easier to understand the content and read faster and more efficiently.

1. **Before** reading the text, and just thinking about title, list 2 things you think will be mentioned in the text.

2. **Before** reading the text, look at the information below about the author. What do you think the author's purpose in writing will be? Write it in 1 sentence.

Author: Anthony Stark, Emergency Medical Responder (EMR). EMRs are specially trained to administer first aid in medical emergencies but are not trained as emergency medical technicians or paramedics.

3. **Next** read the text. What is the author's intent in writing? (For example, the author is writing to warn, inform, persuade...) Write your answer in 1 sentence.

4. What is 1 question you could ask that the text answers?

5. What is a related question that the text does NOT answer?

6. Using another source, find the answer to the question you identified in number 5. Identify your source.

7. Does the excerpt want you to read more of this text or a similar one? Why or why not?

Excerpt from *How to Treat a Dislocation*

A dislocation occurs when two bones that come together in a joint come out of their normal positions. Symptoms of a dislocation include severe pain, immobilization, and deformity of the joint area. Dislocations can occur to nearly any joint of the body, including the shoulders, elbows, knees, hips and ankles; they are also seen in the smaller joints of the fingers and toes. Dislocations are considered urgent situations that require medical care, but you can learn how to treat a dislocation until the patient can receive professional medical help.

Initial Evaluation of the Dislocation

- Cover the dislocated joint with something sterile. It is important to take steps to prevent an infection, especially if there is any broken skin around the area of the dislocation.
- Wait until professional medical personnel arrive before attempting to wash or in any way "clean" the wound (if there is a wound, or if there are any areas of broken skin). Attempting to do so without the proper sterilizing equipment or medical training increases the chance of infection rather than decreasing it.

Immobilize the joint.

- Try to use nonstick gauze if there is an open wound. Note that it is very important not to try and re-position or re-align the joint in any way. This can cause further harm, and it is best to simply immobilize it in the position it is in and to wait for a trained medical professional to definitively treat the dislocation.
- Be sure to immobilize both above and below the dislocated joint to ensure maximum stability while awaiting medical treatment.
- If it is the shoulder that is dislocated, you can use a sling (or make a sling by tying a long piece of fabric into a circle) to immobilize it. Make sure the sling holds the limb against the body. Instead of just wrapping the sling around the neck, try wrapping it around the torso before tying it at the neck.
- If it is another joint such as a knee or elbow, a splint is your best bet. Splints can be constructed of sticks or another stabilizing device and tape or fabric strips to hold the splint in place.

Ref. Stark, A. (2019). How to Treat a Dislocation. <https://www.wikihow.com/Treat-a-Dislocation> (CC BY-NC-SA 3.0)

HANDOUT: Efficient Reading: Building a Drone (3 pages)
Skill Builders: Key Words & Phrases, Skimming, Scanning

IN THE WORKPLACE: People read text for different purposes. Whatever the reason for reading, being able to quickly and accurately find and understand the information you need makes reading both more pleasant and more efficient.

Refer to the excerpt from the text **Building a Drone** to complete the tasks and locate answers to the questions.

Being able to predict content from titles and sub-titles in a document is an effective strategy to make it easier to understand the content and read faster and more efficiently.

1. **Before** reading the text, and just thinking about title, list 2 things you think will be mentioned in the text.

2. **Before** reading the text, look at the information below about the author. What do you think the author's purpose in writing will be? Write it in 1 sentence.

The author describes himself as "I use technology to make the world more open. Linux desktop enthusiast. Map/geospatial nerd. Raspberry Pi tinkerer. Data analysis and visualization geek. Occasional coder. Cloud nativist. Civic tech and open government booster".

3. **Next** reading the text, what is the author's intent in writing? (For example, the author is writing to warn, inform, persuade...) Write your answer in 1 sentence.

4. What is 1 question you could ask that the text answers?

5. What is a related question that the text does NOT answer?

6. Using another source, find the answer to the question you identified in number 5. Identify the source.

7. Does the excerpt want you to read more of this text or a similar one? Why or why not?

Building a Drone

Over the past few years, interest in civilian, military, and commercial drones has grown rapidly, which has also driven the maker community's interest in open source drone projects.

The list of unmanned aerial devices (UAVs) that fit the moniker of drone seems to be constantly expanding. These days, the term seems to encompass everything from what is essentially a cheap, multi-bladed toy helicopter, all the way up to custom-built soaring machines with incredibly adept artificial intelligence capabilities.

Most people are looking for something in the middle. They'd like a flying vehicle that is large enough to support a decently long flight time, hold a camera or other data capture device, and perhaps be able to control some (or all) of its flight autonomously using pre-programmed coordinates or real-time data.

The premade devices in this space vary greatly in both price and build quality, and most of the ones I've seen use proprietary software and hardware. But you don't have to go this route! The drone-building community has created many software and hardware projects under open licenses that allow you to build, repair, customize, and experiment with your own drone, or to supplement the use of drones in some other way. Let's take a look at some of those projects.

Paparazzi UAV: A GPLv2 licensed project that combines both the software and hardware needed to build and fly an open source vehicle under open licenses. Source code and releases of the software components can be found on GitHub, and tutorials for adapting it to off-the-shelf or custom-built hardware can be found on the project's wiki.

ArduPilot: Claims it's "the most advanced, full-featured, and reliable open source autopilot software available." Its features include advanced data-logging, analysis, and simulation tools, and it's supported by a broad ecosystem of third-party sensors, companion computers, and communication systems.

Flone: A cool project that basically turns a smartphone into a drone. It combines a digitally fabricated airframe with software that allows an Android smartphone on the ground to control the one strapped onto the airframe via Bluetooth. It is licensed under GPLv3 and its source code resides on GitHub. English-speaking developers and drone enthusiasts should know that the project is based in Spain and most of the documentation and other materials are in Spanish.

This is definitely an incomplete list of open source drone projects; others you may want to check out include MatrixPilot and AdaPilot.

Ref: Baker, J. (February 12, 2018). 8 open source drone projects. Retrieved from:
<https://opensource.com/article/18/2/drone-projects> CC By-SA 4.0

HANDOUT: Efficient Reading: Solar Power (3 pages)
Skill Builders: Key Words & Phrases, Skimming, Scanning

IN THE WORKPLACE: People read text for different purposes. Whatever the reason for reading, being able to quickly and accurately find and understand the information you need makes reading both more pleasant and more efficient.

Refer to the excerpt from the text **Introduction to Solar Panels** to complete the tasks and locate answers to the questions.

Being able to predict content from titles and sub-titles in a document is an effective strategy to make it easier to understand the content and read faster and more efficiently.

1. **Before** reading the text, and just thinking about title, list 2 things you think will be mentioned in the text.

2. **Before** reading the text, look at the information below about the author. What do you think the author's purpose in writing will be? Write it in 1 sentence.

Author: No author is mentioned by name. The article appears in the education section of a company website. The company has been manufacturing and selling solar panels for over 20 years.

3. **Next** reading the text, what is the author's intent in writing? (For example, the author is writing to warn, inform, persuade...) Write your answer in 1 sentence.

4. What is 1 question you could ask that the text answers?

5. What is a related question that the text does NOT answer?

6. Using another source, find the answer to the question you identified in number 5. Identify the source.

7. Does the excerpt want you to read more of this text or a similar one? Why or why not?

Excerpt from Introduction to Solar Panels

The first solar panels, that resemble today's technology, appeared in the 1950s and were primarily used for space applications. Following the 1970s energy crisis, more R&D and commercial development helped to further the deployment mostly for off-grid applications. In early 2000, Germany was one of the first countries to implement what is called a "fee in tariff" (FIT). FIT is a policy mechanism designed to encourage the adoption of renewable energy sources. As of 2018, over 60 countries had adopted FIT programs including parts of Canada.

FAQ about Solar Panels

Why haven't we seen more solar technologies used in the world today?

The market has been expanding rapidly all over the world. This being said, the initial investment is still relatively expensive. The cost has significantly dropped over the last 15 years and can be, in some cases, cost effective compared to traditional distributed power such as coal, gas, nuclear and hydro especially where grid tied power systems are driven by financial incentives that makes solar panels a very lucrative investment.

What can we power with solar energy?

Solar energy can be used to power all appliances that require electricity. When the system is tied to the grid, the solar energy is exported to the grid. The meter counts the energy "in" and "out". An average Canadian home consumes between 30-50 kWh/day therefore it would take at least a 7-8 kW array to fulfill that energy requirement.

How much does it cost?

The answer is simple; the more you consume energy the more it will cost you. By managing your consumption you can greatly reduce the size of your system and thus, the cost of your system.

However, the cost of your system is dependent not only on your consumption, but also varies depending on the country and the latitude where it will be installed. For a grid tied system without batteries, cost varies around \$7-10/watt and around \$10-25/watt for an off-grid system with batteries.

What are some of the advantages to using solar energy?

- The energy required to fabricate a solar module is produced and paid back within the first year of use. Solar modules are made of materials that are recyclable.
- Solar modules do not pollute or produce any noise and have a life expectancy of more than 25 years.
- It is relatively easy to predict the number of sunlight hours for any given region on the globe.
- For grid-tied installations in urban areas, solar modules produce energy during the peak demand period (9am-5pm and summer cooling) and help to offset this high energy demand.

Ref: Ramatek Energie. (n.d.). About solar PV (solar panels). <https://rematek-energie.com/eng/energy-101/solar-pv.php>

HANDOUT: Efficient Reading: Sports Story (3 pages)
Skill Builders: Key Words & Phrases, Skimming, Scanning

IN THE WORKPLACE: People read text for different purposes. Whatever the reason for reading, being able to quickly and accurately find and understand the information you need makes reading both more pleasant and more efficient.

Refer to the article, **The death of the CWHL presents a new opportunity for women’s professional hockey** to complete the tasks and locate answers to the questions.

Being able to predict content from titles and sub-titles in a document is an effective strategy to make it easier to understand the content and read faster and more efficiently.

1. **Before** reading the text, and just thinking about title, list 2 things you think will be mentioned in the text.

2. **Before** reading the text, look at the information below about the author. What do you think the author’s purpose in writing will be? Write it in 1 sentence.

The author is an Associate Professor in Sport Management and the Director of the Centre for Sport Capacity, at Brock University in St. Catherines, Ontario. She studies historical and current change management in hockey in Canada and around the world.

3. **Next** reading the text, what is the author’s intent in writing? (For example, the author is writing to warn, inform, persuade...) Write your answer in 1 sentence.

4. What is 1 question you could ask that the text answers?

5. What is a related question that the text does NOT answer?

6. Using another source, find the answer to the question you identified in number 5. Identify the source.

7. Does the excerpt want you to read more of this text or a similar one? Why or why not?

The death of the CWHL presents a new opportunity for women’s professional hockey

The sudden announcement by the Canadian Women’s Hockey League (CWHL) that it was ceasing operations has generated controversy and confusion. But as an academic who researches sport organizations, I have a different take — the CWHL closure opens the door for new and innovative women’s professional hockey opportunities.

On the surface, this ordeal reads as a tale of two leagues – one non-profit, the CWHL, and one for-profit, the National Women’s Hockey League (NWHL).

When the CWHL announced it was shutting down, the league’s board of directors stated “the business model has proven to be economically unsustainable.” Many fans and media took this to mean the non-profit model won’t work and the only option is the NWHL’s for-profit approach. But this is a shortsighted view.

Closure is a catalyst for change

The closure of the CWHL is a catalyst for other key stakeholders to enter the scene — which has happened many times in the past for men’s professional hockey, where leagues have come and gone. As my early doctoral research shows, many different stakeholders — including players, hockey federations, government and industry officials — have influenced the development of hockey over time.

The Canadian Amateur Hockey Association, created in 1914, initially resisted popular pressure to allow pay-to-play leagues to emerge. But as players opted for independent leagues that paid them, the CAHA loosened its regulations and accommodated a degree of professionalism while at the same time overseeing the development of hockey in the country.

This shift opened the market to hockey boosters and entrepreneurs, some of whom owned rinks and needed to have an attractive product in order to entice customers. Money-making activity was fast and furious. Leagues came (the National Hockey League started in 1917) and went (the professional National Hockey Association lasted from 1909-18).

Rivalry between leagues

In his account of the emergence of the NHL, academic John Wong says separate camps jockeyed for position and profit as commercial hockey gained public interest. This is no different than the interplay — or as some note, the business rivalry — between the CWHL and NWHL that has unfolded since 2015, when the U.S.-based NWHL formed.

Women’s hockey also attracted economic interests during the early part of the 20th century. In his review of American women’s hockey in the First World War era, Andrew Holman notes that sports entrepreneurs sought new ways to sell the game, and as a result, women’s hockey was positioned as a commercial venture.

The key point Holman makes about this historic time, though, is the rise and fall of the women's game, including its professional form. It is important to note the CWHL story has happened before.

In his examination of hockey capital and the sports industry, historian Andrew Ross notes the complex men's professional hockey landscape has included single-ownership leagues. He points out the NHL was once an unincorporated, non-profit organization.

Not a new model

The key lesson, then, is to recognize the CWHL model was not new and that this approach, as well as others, has existed and failed in the past. More importantly, these models, and the individuals that spearheaded them, pave the way for new and viable professional women's hockey approaches to emerge.

Which brings us to the next phase of the story. In my work on the global development of women's hockey, I note there is no one "best" model, and that each country must develop at its own pace through a method that best suits its unique hockey system. The same is true for a professional women's hockey league.

However, the CWHL's shutdown created a vacuum. Just over 48 hours after the CWHL released news of its decision to close, the NWHL's board announced an investment plan to establish two teams in Canada, and that it received a financial sponsor commitment from the NHL. And so, in a similar fashion to how the NHL and World Hockey Association, a rival men's professional hockey league that existed from 1972-79, merged, one league shuts down while the others acquire some of its franchises and moves on as the lone commercial player in the female game.

Looking back to 2015 when the NWHL was formed, it's interesting to reflect upon the CWHL's response. The CWHL commissioner at the time, Brenda Andress, commented that the NWHL model was wrong and "that for us, it's about sound operational and financial foundations first because we want to ensure the viability of the long term."

During its 12 years of operation, the CWHL took this approach and in so doing, shaped the professional women's hockey landscape. It's now time for the next stage.

Covered under Creative Commons license Attribution-NoDerivatives 4.0 International (CC BY-ND 4.0)

Stevens, J. (April 3, 2019). The death of the CWHL presents a new opportunity for women's professional hockey. Retrieved from: https://theconversation.com/the-death-of-the-cwhl-presents-a-new-opportunity-for-womens-professional-hockey-114802?utm_source=timminstoday.com&utm_campaign=timminstoday.com&utm_medium=referral

HANDOUT: Efficient Reading: White Fang (Fiction) (3 pages)
Skill Builders: Key Words & Phrases, Skimming, Scanning

IN THE WORKPLACE: People read text for different purposes. Whatever the reason for reading, being able to quickly and accurately find and understand the information you need makes reading both more pleasant and more efficient.

Refer to the excerpt from the text **White Fang** to complete the tasks and locate answers to the questions.

Being able to predict content from titles and sub-titles in a document is an effective strategy to make it easier to understand the content and read faster and more efficiently.

1. **Before** reading the text, and just thinking about title, list 2 things you think will be mentioned in the text.

2. **Before** reading the text, look at the information below about the author. What do you think the author's purpose in writing will be? Write it in 1 sentence.

Author: Jack London was an American novelist, journalist, and social activist using his platform to inform the public about animal cruelty. A pioneer in the world of commercial magazine fiction, he was one of the first writers to become a worldwide celebrity and earn a large fortune from writing.

3. **Next** reading the text, what is the author's intent in writing? (For example, the author is writing to warn, inform, persuade...) Write your answer in 1 sentence.

4. What is 1 question you could ask that the text answers?

5. What is a related question that the text does NOT answer?

6. Using another source, find the answer to the question you identified in number 5. Identify the source.

7. Does the excerpt want you to read more of this text or a similar one? Why or why not?

Excerpt from *The Call of the Wild*

[Note: The story is told from the point of view of White Fang, a domesticated wolf.]

Had there been in White Fang's nature any possibility, no matter how remote, of his ever coming to fraternize with his kind, such possibility was irretrievably destroyed when he was made leader of the sled-team. For now the dogs hated him -- hated him for the extra meat bestowed upon him by Mit-sah; hated him for all the real and fancied favors he received; hated him for that he fled always at the head of the team, his waving brush of a tail and his perpetually retreating hind-quarters forever maddening their eyes.

And White Fang just as bitterly hated them back. Being sled-leader was anything but gratifying to him. To be compelled to run away before the yelling pack, every dog of which, for three years, he had thrashed and mastered, was almost more than he could endure. But endure it he must, or perish, and the life that was in him had no desire to perish. The moment Mit-sah gave his order for the start, that moment the whole team, with eager, savage cries, sprang forward at White Fang.

There was no defence for him. If he turned upon them, Mit-sah would throw the stinging lash of the whip into his face. Only remained to him to run away. He could not encounter that howling horde with his tail and hind-quarters. These were scarcely fit weapons with which to meet the many merciless fangs. So run away he did, violating his own nature and pride with every leap he made, and leaping all day long.

One cannot violate the promptings of one's nature without having that nature recoil upon itself. Such a recoil is like that of a hair, made to grow out from the body, turning unnaturally upon the direction of its growth and growing into the body -- a rankling, festering thing of hurt. And so with White Fang. Every urge of his being impelled him to spring upon the pack that cried at his heels, but it was the will of the gods that this should not be; and behind the will, to enforce it, was the whip of cariboo-gut with its biting thirty-foot lash. So White Fang could only eat his heart in bitterness and develop a hatred and malice commensurate with the ferocity and indomitability of his nature.

Ref: London, J. (2008). *The Call of the Wild*. <https://www.gutenberg.org/files/215/215-h/215-h.htm>

HANDOUT: Changes in the Electrical Code (3 pages)
Skill Builders: Key Words & Phrases, Skimming, Scanning

IN THE WORKPLACE: The 24th edition of the Canadian Electrical Code (2018) contains a number of significant changes and updates to better ensure safe installation and maintenance of electrical equipment in order to prevent hazards and ensure proper maintenance and operation. It is the responsibility of apprentices and journeypersons to be certain their work is consistent with the latest version of the Code.

Refer to the article **Changes in the 2018 Electrical Code** and your own research to complete the tasks and locate answers to the questions.

1. What do each of the following acronyms stand for?

a) EVSE: _____

b) GFCI: _____

c) LED: _____

d) TR: _____

2. What does the term “wet areas” refer to?

3. What voltage LEDs are affected by the 2018 change?

4. What new rules and subrules also refer to the provision of power related to electric vehicles?

Changes in the 2018 Electrical Code

The 2018 Canadian Electrical Code, Part I includes a number of significant updates and changes to better help electrical workers in the safe maintenance of electrical equipment and create safer electrical installations. **Here are 4 key changes.**

1. Disconnecting means for LED luminaires

2015 Code — disconnecting means required for fluorescent ballasts

2018 Code — disconnecting means required for fluorescent ballasts and LED drivers

To support safe maintenance, the Code has for several editions required disconnecting means for fluorescent luminaires utilizing double ended lamps and operating at more than 150 V. With increased use of LED lighting, the requirements have been extended to LED luminaires exceeding 150 V to ground with double ended lamps.

2. Tamper resistant (TR) receptacles

2015 Code — TR receptacles required in dwelling units and child care facilities

2018 Code — TR receptacles required in additional occupancy types

The requirement for tamper resistant receptacles in dwelling units and child care facilities is expanded to include other areas where children may be present including hotel guest rooms, preschools, and elementary education facilities.

3. Increased GFCI protection for wet areas

2015 Code — No requirement for GFCI protection for heaters or controls in bathrooms

2018 Code — GFCI protection required

Similar to GFCI requirements for receptacles in the vicinity of showers, sinks or tubs, new Section 62 Rules mandate GFCI protection for electric heating devices and heating controls in the vicinity of sinks, showers or tubs.

4. Electric vehicle energy management system

2015 Code — EV supply equipment loads added to load calculations at 100% of rating

2018 Code — demand factors recognized where energy management system used.

Electric vehicle supply equipment (EVSE) can draw a substantial load when in the charging mode. For existing buildings, the addition of EVSE can result in the total load exceeding the existing service capacity. In this case, the first option is to increase the service size. A second option is to install a system to monitor the power being drawn by EVSEs and other building loads, and control the EVSE loads such that the overall load does not exceed the limits of the existing service, feeders, and branch circuits. In combination with new Rule 8-500 and new Subrules 8-106(11) and (12) such systems are now recognized in the Code as Electric Vehicle Energy Management Systems (EVEMS). Complementary to the introduction of EVEMS, a new Table of loads and demand factors has been added specifically for EVSE.

Ref: Electrical Industry Newsweek. (June 28, 2018). 2018 Canadian Electrical Code, Part I: Top 15 Changes. <https://www.electricalindustry.ca/latest-news/3739-2018-canadian-electrical-code-part-i-top-15-changes>

HANDOUT: Demand for Skilled Trades (4 pages)
Skill Builders: Key Words & Phrases, Skimming, Scanning

IN THE WORKPLACE: Skilled trades are a significant factor in, and contributor to, the strength of the Canadian economy. Understanding how your work contributes, and staying current on trades' trends in the news, is part of taking professional pride in your work.

Refer to the article **Skilled trade jobs go begging in Canada** to locate answers to the questions.

Being able to predict content from titles and sub-titles in a document is an effective strategy to make it easier to understand the content and read faster and more efficiently.

1. **Before** reading the article, and just from looking at the title, list 3 topics you expect to find mentioned in the article.

2. Who authored the report referred to?

3. How many employers participated in the survey? _____

4. According to the article, what is a large organization?

5. A "gap" is the distance between 2 things or sides. What are the 2 sides of the skillsgap?

6. Articles often use a lot of “jargon” or words that are specific to the topic being discussed. In your own words, write a definition for each of the following jargon words used in the human resources sector:

a. Boomerang retirees

b. Upskilling

c. Reskilling

d. Learning platform

e. Adjacent skills

f. Skilled trade

7. Complete the following table.

%	Of employers...
	... are changing their existing work models
41%	
	... are investing in learning platforms
58%	
56%	

8. Identify 2 things that employers are doing to attract new employees.

9. The article focuses on what employers can do to fill jobs. What is an example of something a worker can do?

10. Now that you've read the article, look back at your prediction in Question 1. Did your predictions match the content of the article? What do you think would be a different good title for the article?

Skilled trade jobs go begging in Canada

Skilled trades are the hardest jobs to fill

A new report by ManpowerGroup finds that 41 per cent of Canadian employers say they can't find the skilled people they need to fill jobs.

"We continue to see increasing demand for skilled workers across all sectors of the Canadian economy from trades and transport to sales," said Darlene Minatel, country manager of ManpowerGroup Canada. "Today's job seekers don't always have the skills employers need. To solve our growing skills gap, we need to take a new approach.

"Employers need to buy skills in the short term, cultivate communities of talent by borrowing from external sources and help people with adjacent skills transition from one role to another. Above all, we need to build talent through upskilling and reskilling programs to develop a workforce with the skills companies and individuals need to succeed.

The ManpowerGroup 2018 Talent Shortage Survey, which was released on Monday, said skilled trades are the hardest jobs to fill in Canada, followed by sales representatives and drivers.

"At a time when organizations face a tightening labour market and the lowest unemployment in 40 years, most of the jobs where demand is growing are mid-skilled roles that require post-secondary training, yet not always a full university degree," said Manpower.

"Nearly three in four of the companies surveyed (68 per cent) are investing in learning platforms and development tools to build their talent pipeline, while 28 per cent of employers are changing their existing work models, including offering flexible work arrangements to attract and retain talent, according to the nearly 2,000 employers surveyed. More than half of companies (56 per cent) are looking at different talent pools for skills, including boomerang retirees or returning parents and part-timers."

Manpower said that globally, 45 per cent of employers say they can't find the skills they need. Large organizations (250-plus employees) are struggling the most: more than half (58 per cent) of large organizations in Canada reported talent shortages this year.

Ref: Toneguzzi, M. (August 20, 2018). Skilled trade jobs go begging in Canada.
<https://troymedia.com/business/skilled-trade-jobs-go-begging-canada/>

HANDOUT: Finding Information in Codes: Building (4 pages)
Skill Builders: Key Words & Phrases, Skimming, Scanning, Navigating Regulations

IN THE WORKPLACE: The National Building Code applies mainly to new construction, but also to aspects of demolition, relocation, and renovation. Provinces and territories can adopt the National Code or adapt it to their own jurisdictions. It is the responsibility of workers to be certain their work is consistent with the latest version of the Code.

Refer to the excerpt of the **BC Building Code** to complete the tasks and locate answers to the questions.

- Using the following structure, complete the table below using the information in the excerpt. Locate and use the first example that allows you to complete every line in the structure. The first line is done for you.

3	Part
3-5	Section
3-5.2	Sub-section
3-5.2.1	Article
3-5.2.1 (2)	Sentence
3-5.2.1 (2) (a)	Clause
3-5.2.1.(2) (a) (i)	Subclause

Division	B: Acceptable Solutions
Part	
Section	
Sub-section	
Article	
Sentence	
Clause	
Subclause	

- What are the 3 main categories of information in sub-section 3.8.2?

3. Angles brackets < > are used to indicate changes between the current and previous versions of the Code. How many changes are indicated in 3.8.2.1 and what do they refer to?

4. What is the rule number that governs openings through firewalls?

5. Under what circumstances must more than 1 universal toilet room be provided?

6. What size units does subsection 3.8.2 apply to?

7. Where can you find more information on Group C apartment buildings?

8. How many specific requirements are identified in 3.8.2.3 (1)?

9. What 2 parking options are permitted? Provide the full rule number where you found the answer.

10. Does this excerpt from the building code apply to new construction only? Provide the full rule number where you found the answer.

DIVISION B ACCEPTABLE SOLUTIONS

Part 3 — Fire Protection, Occupant Safety and Accessibility

Section 3.8. Building Requirements for Persons with Disabilities

3.8.1. GENERAL

3.8.1.1. Application

- 1)** This Section applies to the design and construction of *buildings* and *occupancies* to make them *accessible by persons with disabilities*.
- 2)** The requirements of this Section take precedence over other requirements contained in this Part and in Part 9.
- 3)** Access shall be provided to *alterations*, additions and changes in *occupancy* to the extent required in Subsection 3.8.4.

3.8.1.2. Openings through Firewalls

- 1)** Where there are openings through a *firewall*, other than those for piping, tubing, wiring and conduit, the requirements of this Section shall apply to the *floor areas* on both sides of the *firewall* as if they were in the same *building*.

3.8.2. CLASSIFICATION REQUIREMENTS

3.8.2.1. Application and Exemptions

- 1)** Except as provided in Sentence (2), access shall be provided to all *storeys* of *buildings* of new construction.
- 2)** This Subsection does not apply to
 - a) the *storey* next above or below the *accessible storey* in a *building* not more than two *storeys* in *building height* provided the *storeys* next above or below the *accessible storey*
 - i) is less than 600 m² in *floor area*,
 - ii) does not contain *facilities* integral to the principle function of the *accessible storey*, and
 - iii) does not contain an assembly major occupancy with an area more than 100 m², (See Appendix A.)
 - b) the *storey* next above or below the *accessible storey* in a *suite* of not more than two *storeys*, where the *accessible storeys* is the first *storey* or basement, provided the *storey* next above or below the *accessible storey*

- i) is less than 600 m² in area,
- ii) does not contain *facilities* integral to the principle function of the *accessible storey*, and
- iii) does not contain an assembly *major occupancy* with an *area* more than 100 m²,
- c) Group C *dwelling units*, row houses, boarding houses and lodging houses,
- d) Group C apartment *buildings* and condominiums except to the extent described in Article 3.8.2.27.,
- e) Group E shops and stores with a total retail floor space of less than 50 m² (See Appendix A), and ➤
- f) Group F Division 1 *occupancies*.

3.8.2.2. Design Requirements

1) To meet the requirements of Articles 3.8.2.3. to 3.8.2.39., the design requirements of Subsection 3.8.3. shall form an integral part of this Subsection.

3.8.2.3. Specific Requirements

1) Except where stated otherwise *buildings* and *occupancies* to which this Subsection applies shall, in addition to the requirements listed for specific *occupancies*, have

- a) *access* from the street to at least one main entrance conforming to Article 3.8.3.5.,
- b) where off-street parking is provided for *persons with disabilities*, ~~access~~ from the parking area to an entrance conforming to Article 3.8.3.5. ~~that~~ serves the parking area unless the entrance in Clause (a) is located so as to conveniently serve both the parking area and the *street*,
- c) access to all areas where work functions can reasonably be expected to be performed by *persons with disabilities*,
- d) accessible washrooms conforming to Sentence (2), and
- e) on each floor area to which *access* is required, egress conforming to Article 3.8.3.19.

2) In *buildings* and *occupancies* where water closets are required,

- a) at least one universal toilet room ~~that~~ conforms to Sentence 3.7.2.10.(9) ~~shall be provided~~ , and
- b) where the *occupant load* of the *building* or *occupancy* exceeds 150, other public washrooms in floor areas required to be *accessible* shall conform to Sentences 3.7.2.10.(2) to (8).

THESE MATERIALS ARE NOT AN OFFICIAL VERSION. These materials contain information that has been derived from information originally made available by the Province of British Columbia at: free.bcpublications.ca/civix/content/public/?xsl=/templates/browse.xsl and this information is being used in accordance with the Queen's Printer Model Codes License – British Columbia. They have not, however, been produced in affiliation with, or with the endorsement of, the Province of British Columbia.

Ref: BC Building Code. (2012). Section 3.8. building requirements for persons with disabilities. In Part 3 — fire protection, occupant safety and accessibility. http://free.bcpublications.ca/civix/document/id/public/bcbc2006/building_b_p3_3.8

HANDOUT: Finding Information in the Code: Electrical (4 pages)
Skill Builders: Key Words & Phrases, Skimming, Scanning, Navigating Regulations

IN THE WORKPLACE: The purpose of the Canadian Electrical Code is to ensure safe installation and maintenance of electrical equipment in order to prevent hazards and ensure proper maintenance and operation. It is the responsibility of apprentices and journeypersons to be certain their work is consistent with the latest version of the Code.

Refer to **Section 86: 2018 Electrical Code** to complete the tasks and locate answers to the questions.

1. What are the 4 main categories of information in Section 86?

2. What are the rule and/or subrule numbers of information that is new in this version of the Code?

3. Complete the rule number for control and protection: 8 - 00

4. Complete the rule number for voltages: 8_ - _____

5. Complete the rule number for connected loads: 6 - 0_

6. What information must be included on warning signs?

7. What vehicle types are not covered by Section 86?

8. What is the maximum voltage for vehicles covered under Section 86?

9. Where can you find more information on branch circuits?

10. What 3 conditions must be met for the vehicle supply equipment to be considered disconnected?

11. What are 3 sources of electrical current to vehicle motors?

12. Where can you find more information on the max connected load?

13. What provision must be made for a charging receptacle installed outside?

14. When is it permissible to supply equipment from a branch circuit that is supplying another load as well? Provide the full rule number where you found the answer.

Section 86 — Electric vehicle charging systems

Scope

86-000 Scope

This Section applies to the installation of

- a) the insulated conductors and cables and the equipment external to an electric vehicle that connect it to source of electric current by conductive or inductive means; and
 - b) equipment and devices related to electric vehicle charging.
- 2) This Section supplements or amends the general requirements of this Code.

General

86-100 Special terminology (see Appendix B)

In this Section, the following definitions shall apply:

Electric vehicle — an automotive-type vehicle for use on public roads that

- a) includes automobiles, buses, trucks, vans, low-speed vehicles, motorcycles, and similar vehicles powered by one or more electric motors that draw current from a fuel cell, photovoltaic array, rechargeable energy storage system (such as a battery or capacitor), or other source of electric current;
- b) includes plug-in hybrid electric vehicles (PHEVs); and
- c) excludes off-road electric vehicles, such as industrial trucks, hoists, lifts, transports, golf carts, airline ground support equipment, tractors, and mobility scooters for persons with disabilities.

Electric vehicle connector — a device that, when electrically coupled to a mating device on the electric vehicle, establishes means for power transfer and information exchange between an electric vehicle and electric vehicle supply equipment.

Δ Electric vehicle supply equipment (EVSE) — a complete assembly consisting of cables, connectors, devices, apparatus, and fittings installed for the purpose of power transfer and information exchange between the branch circuit and the electric vehicle.

Plug-in hybrid electric vehicle (PHEV) — a type of electric vehicle having an additional energy source for motive power.

86-102 Voltages

The nominal ac system voltages used to supply equipment covered in this Section shall not exceed 750 V.

86-104 Permanently connected and cord-connected equipment

Rules 86-300 to 86-404 apply to installation of permanently connected and cord-connected electric vehicle supply equipment.

Equipment

86-200 Warning sign

Permanent, legible signs shall be installed at the point of connection of the electric vehicle supply equipment to the branch circuit wiring, warning against operation of the equipment without sufficient ventilation as recommended by the manufacturer's installation instructions.

Control and protection

86-300 Branch circuits (see Appendix B)

- 1) Electric vehicle supply equipment shall be supplied by a separate branch circuit that supplies no other loads except ventilation equipment intended for use with the electric vehicle supply equipment.
- Δ 2) Notwithstanding Subrule 1), electric vehicle supply equipment shall be permitted to be supplied from a branch circuit supplying another load(s), provided that an electric vehicle energy management system is installed in accordance with Subrule [8-106](#) 11) or 12).
- 3) For the purposes of Subrule 2), the calculated demand shall be determined in accordance with Section [8](#).

86-302 Connected load

The total connected load of a branch circuit supplying electric vehicle supply equipment and the ventilation equipment permitted by Rule [86-300](#) shall be considered continuous for the purposes of Rule [8-104](#).

86-304 Disconnecting means

- A separate disconnecting means shall be provided for each installation of electric vehicle supply equipment rated at 60 A or more, or more than 150 volts-to-ground.
- 2) The disconnecting means required in Subrule 1) shall be
 - a) on the supply side of the point of connection of the electric vehicle supply equipment;
 - b) located within sight of and accessible to the electric vehicle supply equipment; and
 - c) capable of being locked in the open position.

86-306 Receptacles for electric vehicle supply equipment (see Appendix B)

- 1) Each receptacle for the purpose of electric vehicle charging shall be labelled in a conspicuous, legible, and permanent manner, identifying it as an electric vehicle supply equipment receptacle and shall be
 - a) a single receptacle of CSA configuration 5-20R supplied from a 125 V branch circuit rated not less than 20 A; or
 - b) of the appropriate CSA configuration in accordance with Diagram [1](#) or [2](#) when supplied from a branch circuit rated at more than 125 V or more than 20 A.
- 2) When the receptacle referred to in Subrule 1) a) is installed outdoors and within 2.5 m of finished grade, it shall be protected with a ground fault circuit interrupter of the Class A type.

Adapted from source: **CSA C22.1-18 Canadian Electrical Code (24th edition), Part 1 Safety Standard for Electrical Installations**. © 2018 Canadian Standards Association. Please visit store.csagroup.org

HANDOUT: Finding Information in Codes: Plumbing (4 pages)

Skill Builders: Key Words & Phrases, Skimming, Scanning, Navigating Regulations

IN THE WORKPLACE: The National Plumbing Code of Canada sets out technical provisions for the design and installation of new plumbing systems and also applies to the extension, alteration, and repair of existing plumbing systems. Provinces and territories can adopt the National Code or adapt it to their own jurisdictions. It is the responsibility of workers to be certain their work is consistent with the latest version of the Code.

Refer to the excerpt of the **BC Plumbing Code** to complete the tasks and locate answers to the questions.

- Using the following structure, complete the table below using the information in the excerpt. Locate and use the first example that allows you to complete every line in the structure. The first line is done for you.

3	Part
3-5	Section
3-5.2	Sub-section
3-5.2.1	Article
3-5.2.1 (2)	Sentence
3-5.2.1 (2) (a)	Clause
3-5.2.1.(2) (a) (i)	Subclause

Division	B: Acceptable Solutions
Part	
Section	
Sub-section	
Article	
Sentence	
Clause	
Subclause	

- What are the 3 main categories of information in section 2.5?

3. Angles brackets < > are used to indicate changes between the current and previous versions of the Code. How many changes are indicated in 2.5.2 and what do they refer to?

4. What is the full rule number that governs outlet pipes of less than 2 inches?

5. Under what circumstances does a trap not need to be protected by a vent pipe?

6. What size offset is permitted for pipes larger than 2 inches?

7. Where can you find more information on additional protections for drainage systems?

8. How many clauses are identified in 2.5.2.1?

9. What is the maximum number of fixtures that can be connected to a combined relief and circuit vent? Provide the full rule number where you found the answer.

10. What 3 rules refer to emergency floor drains?

Copyright notice:

THESE MATERIALS ARE NOT AN OFFICIAL VERSION. These materials contain information that has been derived from information originally made available by the Province of British Columbia at: free.bcpublications.ca/civix/content/public/?xsl=/templates/browse.xsl and this information is being used in accordance with the Queen's Printer Model Codes License – British Columbia. They have not, however, been produced in affiliation with, or with the endorsement of, the Province of British Columbia.

DIVISION B
ACCEPTABLE SOLUTIONS

Part 2 — Plumbing Systems

Section 2.5 Venting Systems**2.5.1. VENTING FOR TRAPS**

2.5.1.1. Venting for Traps

1) Except as provided in Sentences (3) and (4), every *trap* shall be protected by a *vent pipe*.

2) *Drainage systems* may require additional protection as provided in Subsection 2.5.4.

3) A *trap* that serves a floor drain need not be protected where

- a) the *size* of the *trap* is not less than 3 inches,
- b) the length of the *fixture drain* is not less than 450 mm, and
- c) the fall on the *fixture drain* does not exceed its *size*.

4) A *trap* need not be protected by a *vent pipe*

a) where it serves

i) a *subsoil drainage pipe*, or

ii) a *storm drainage system*, or

b) where it forms part of an indirect *drainage system*. (See also Clause 2.4.2.3.(2)(b).)

2.5.2. WET VENTING

2.5.2.1. Wet Venting

1) A *soil-or-waste pipe* may serve as a *wet vent* provided that

a) the hydraulic load is in accordance with Table 2.5.8.1,

b) the number of wet-vented water closets does not exceed 2,

c) where 2 water closets are installed, they are connected at the same level by means of a double sanitary T fitting if the *vent pipe* is vertical and by means of a double Y fitting if the *vent pipe* is horizontal,

d) the water closets are installed downstream of all other *fixtures*,

e) *trap arms* and *fixture drains* connected to the *wet vent* do not exceed 2 inches in *size*, except for connections from *emergency floor drains* in accordance with Sentence 2.5.1.1.(3),

- f) the total hydraulic load on the *wet vent* does not exceed the limits stated in Table 2.5.8.1, when separately vented *branches* or *fixture drains* in the same *storey*, having a total hydraulic load not greater than 2 *fixture units*, are connected to the *wet vent* or a wet-vented water closet *trap arm*,
- g) the hydraulic load of separately vented *fixtures* that drain into the *wet vent* are not included when sizing the *continuous vent* that serves the *wet vent*,
- h) where a *wet vent* extends through more than one *storey*, the total discharge from any one *storey* above the first *storey* does not exceed 4 *fixture units*,
- i) there is not more than one *nominally horizontal offset* in the *wet vent*, and
- i) the *offset* does not exceed 1.2 m for pipes 2 inches or less in *size*, or ii) the *offset* does not exceed 2.5 m for pipes larger than 2 inches in *size*,
- j) the wet-vented portion is not reduced in *size* except for the portion that is upstream of *emergency floor drains* in accordance with Sentence 2.5.1.1.(3), and
- k) the length of the *wet vent* is not limited.

2.5.3. CIRCUIT VENTING

2.5.3.1. Circuit Venting

- 1)** A section of horizontal *branch* may be circuit-vented provided
- a *circuit vent* is connected to it,
 - all *fixtures* served by the *circuit vent* are located in the same *storey*, and
 - no *soil-or-waste stack* is connected to it upstream of a circuit-vented *fixture*.
- 2)** *Fixtures* with *fixture outlet pipes* less than 2 inches in *size* shall be separately vented or separately circuit-vented.
- 3)** Except as provided in Sentences (4) and (5), a *relief vent* shall be connected to the *branch* that forms part of a circuit-vented system, downstream of the connection of the most downstream circuit-vented *fixture*.
- 4)** A symmetrically connected *relief vent* may serve as a combined *relief vent* for a maximum of 2 *branches* that are circuit-vented, provided there are not more than 8 circuit-vented *fixtures* connected between the combined *relief vent* and each *circuit vent*.

Ref: BC Publications. (2012). Section 2.5. Venting Systems. In Part 2 Venting Systems.
<http://free.bcpublications.ca/civix/document/id/public/vpbl2014/ep001002.5>

HANDOUT: Occupational Health and Safety Regulations (3 pages)
Skill Builders: Key Words & Phrases, Navigating Regulations

IN THE WORKPLACE: Being able to navigate *Occupational Health and Safety Regulations* protects workers from risks to their health and safety, and also helps them identify their own responsibilities related to workplace safety.

1. What is the title of section 2.3?

2. In your own words, what is section 2.3 about?

3. Who is this regulation written for?

4. As a result of section 2.3 (1), what is the appearance of most public swinging doors?

5. If a gate or door opens into a hallway, what document would tell you how wide the hallway needs to be?

6. Underline 3 terms that you think should be defined in the *Interpretations* section at the beginning of Part II. Google the definition for each and write them below.

7. How is section 2.12 formatted to make it easier to read?

8. How far apart do supporting posts need to be spaced?

9. How tall should the guardrail be?

10. Label the picture consistent with parts a), b) and c) of 2.12 (1).



Excerpts from the *Canada Occupational Health and Safety Regulations***Doors**

2.3 (1) Every double-action swinging door that is located in an exit, entrance or passageway used for two-way pedestrian traffic or traffic involving wheelchairs or other similar devices shall be designed and fitted in a manner that will allow persons who are approaching from one side of the door to be aware of persons who are on the other side of it.

(2) The area of every passageway into which a door or gate extends when open, other than the door of a closet or other small unoccupied storage room, shall be marked, in consultation with the work place committee or the health and safety representative in a manner that clearly indicates the area of hazard created by the opening of the door or gate.

(3) Where a door or gate that is to remain open extends into a passageway for a distance that will reduce the effective width of the passageway to a width less than that required by the National Building Code,

Portes

2.3 (1) Toute porte va-et-vient située à une sortie, à une entrée ou à un passage servant à la circulation dans les deux sens des piétons ou des personnes utilisant un fauteuil roulant ou autre appareil du même genre doit être conçue et installée de manière à permettre aux personnes qui s'en approchent de se rendre compte de la présence de celles se trouvant de l'autre côté.

(2) L'aire de tout passage sur laquelle empiète une porte ouverte autre que la porte d'un placard ou d'une petite pièce inoccupée servant à l'entreposage doit, en consultation avec le comité local ou le représentant, être marquée de façon à indiquer clairement la zone de risque ainsi créée.

(3) Lorsqu'une porte devant demeurer ouverte rend la largeur utilisable d'un passage inférieure à la largeur exigée par le Code canadien du bâtiment, l'une des mesures suivantes doit être prise :

Guardrails

2.12 (1) Every guardrail shall be highly visible and consist of

- (a)** a horizontal top rail not less than 900 mm but not more than 1 100 mm above the base of the guardrail;
- (b)** a horizontal intermediate rail spaced midway between the top rail and the base; and
- (c)** supporting posts spaced not more than 3 m apart at their centres.

(2) Every guardrail shall be designed to withstand a static load of 890 N applied in any direction at any point on the top rail.

SOR/94-263, s. 8(F); SOR/2000-374, s. 2.

Garde-fous

2.12 (1) Tout garde-fou doit être très visible et être constitué :

- a)** d'une traverse horizontale supérieure située à au moins 900 mm mais à au plus 1 100 mm au-dessus de la base;
- b)** d'une traverse horizontale intermédiaire située à égale distance de la traverse supérieure et de la base;
- c)** de poteaux de soutènement séparés par une distance d'au plus 3 m d'un point milieu à l'autre.

(2) Tout garde-fou doit être conçu pour supporter une charge statique de 890 N appliquée en quelque sens que ce soit sur tout point de la traverse supérieure.

DORS/94-263, art. 8(F); DORS/2000-374, art. 2.

Government of Canada. (June 25, 2019). Canada occupational health and safety regulations. <https://laws-lois.justice.gc.ca/PDF/SOR-86-304.pdf>

HANDOUT: Heat Stress Safety Bulletin (3 pages)
Skill Builders: Key Words & Phrases, Skimming, Scanning

IN THE WORKPLACE: It is the shared responsibility of workers and employers to ensure that workplaces are free from accidents, injuries, illnesses or fatalities. Being aware of specific health risks associated with working out of doors during warm days, helps catch potential issues before they arise.

Read **The Hazards of Heat Stress** safety bulletin to locate answers to the questions.

1. In your own words, what causes heat stress?

2. What types of heat-related illness do not usually require medical attention?

3. In what cases can heat stress cause death?

4. Complete the following:

Heat_____happens when the body loses too much water. Heat_____may appear on the body. Heat_____are felt in the body. One sign of heat _____ is nausea. The most serious heat-related_____is heat _____.

5. Changes in heart rate can indicate heat stress. What could the following indicate?

a) Fast heart rate _____

b) Slow heart rate _____

6. Whose responsibility are each of the following? Put an X in the column.

Prevention Tip	Workers	Managers
1. Wear light fitting clothing		
2. Schedule hot jobs in morning		
3. Avoid coffee		
4. Monitor personal health		
5. Provide breaks		
6. Drink water		

7. Taylor has been working outside all summer. Last night, several of the crew went out for beers after work. This morning Taylor has had a couple of iced-coffee to stay cool and alert but now suddenly feels cramping in both legs.

a) What do you think the problem is?

b) What are 2 things that can be done to treat the problem?

c) What are 2 things that Taylor could have done to prevent the problem?

THE HAZARDS OF HEAT STRESS



Heat and humidity are a normal part of Ontario summers, but how your body reacts to the heat depends on how hard you are working, how much water you have been drinking, how fit you are, and whether you have become acclimatized to the higher temperatures.

Heat stress can occur wherever physical work is being done in a hot, humid environment. The body tries to cool itself by increasing the heart rate to move blood—and heat—to the skin and by sweating to help cool the blood and body. But when too much water is lost through sweating, dehydration occurs. This can lead to heat-related illnesses.

Illness	Symptoms	Treatment	Severity
Heat Rash	<ul style="list-style-type: none"> Red blotches and extreme itchiness in areas persistently damp with sweat Prickling sensation on the skin where sweating occurs 	<ul style="list-style-type: none"> Rest in a cool place. Take a shower or rinse skin with cool water. Change into dry clothes. 	If treated, symptoms usually disappear after a few days.
Heat Cramps	<ul style="list-style-type: none"> Painful cramps or spasms in the arms, legs, back, or stomach that occur suddenly at work or later at home Hard, painful lumps in the muscles as a result of the cramps 	<ul style="list-style-type: none"> Rest in a cool place. Remove or loosen clothing. Drink cool water or a sports drink containing electrolytes. Stretch and massage muscles. If the cramps are severe or don't go away, seek medical aid. 	If not treated promptly, heat cramps can lead to more serious heat-related illnesses.
Fainting	<ul style="list-style-type: none"> Sudden fainting after at least two hours of work Cool, moist skin Weak pulse 	<ul style="list-style-type: none"> GET MEDICAL ATTENTION. Assess the need for CPR. Rest in a cool place. Remove or loosen clothing. If conscious, make the person lie down. If conscious, give the person sips of cool water. 	If not treated promptly, fainting can lead to more serious heat-related illnesses. Fainting may also be due to other illnesses.
Heat Exhaustion	<ul style="list-style-type: none"> Weakness Headache Breathlessness Nausea or vomiting Feeling faint 	<ul style="list-style-type: none"> GET MEDICAL ATTENTION. Rest in a cool place. Remove or loosen clothing. Lie down with feet raised. Drink cool water or a sports drink containing electrolytes. Do not leave affected person alone. Take a cool shower or rinse skin with cool water. 	If not treated promptly, heat exhaustion can lead to heat stroke, which can be fatal.
Heat Stroke	<ul style="list-style-type: none"> Irrational behaviour Confusion Loss of consciousness (fainting) Convulsions Hot, dry skin (not sweating) Rapid heartbeat Rapid and shallow breathing 	<ul style="list-style-type: none"> GET MEDICAL ATTENTION. Call 911 or get the person to hospital immediately. Move the person out of the sun and into a cool place. Cool the person's body by covering with damp sheets, spraying with cool water, or using a fan. If conscious, give the person sips of cool water. 	Can be fatal if medical assistance is not obtained immediately.

Source: ontario.ca/heatstress (reviewed December 2015)

Symptoms of heat stress should never be ignored. They are your body's way of telling you that something needs to be done to balance your body's heating and cooling system. For more information on heat stress and helpful resources on how to prevent it, visit the **Heat Stress** topic page on ihsa.ca.

Prevention tips for workers

- Be aware of the symptoms.** Watch out for symptoms of heat stress in yourself and your co-workers.
- Drink water.** You need to drink one cup of cool water every 20 minutes, even if you're not thirsty.
- Avoid alcohol and caffeinated drinks.** Alcohol and caffeinated beverages such as tea, coffee, and cola are diuretics and will dehydrate your body. These drinks should also be avoided the night before work as well.
- Wear light, loose-fitting clothing.** Wear clothes that allow sweat to evaporate. Light-coloured garments absorb less heat from the sun.
- Know your personal risk factors.** Any of the following conditions could increase your risk for heat-related illness: excessive weight, poor physical condition, previous heat-related illnesses, older age, heart disease, high blood pressure, recent illnesses, and certain medications.

Prevention tips for managers/supervisors

- Training.** Make heat stress your next safety talk and remind workers about it periodically throughout the summer. Visit ihsa.ca for free safety talks on heat stress and sun protection.
- Breaks.** Give workers frequent breaks in cool areas.
- Scheduling.** Schedule hotter jobs during cooler parts of the day.
- Assistance.** Minimize strenuous tasks by pairing up workers or providing material handling equipment such as carts, dollies, pallet jacks, or manual forklifts.

IHSA013

Rev. 2016



Ref: ISHA (2016). Heat Stress Safety Poster. [Poster]. https://www.ihsa.ca/pdfs/topics/Heat_Stress_Poster.pdf

HANDOUT: Lockout Procedure (4 pages)
 Skill Builders: Key Words & Phrases, Skimming, Scanning

IN THE WORKPLACE: Following detailed step by step instructions to safely install, operate and shutdown machinery is part of most tradesperson’s work. Errors in sequencing steps or skipping them altogether can result in accidents and lost time.

Read **SAMPLE 1** and **SAMPLE 3: Lockout Procedures** to locate answers to the questions. Write the answers in the space provided.

1. Who is the intended audience for SAMPLE 1?

2. Who is the intended audience for SAMPLE 3?

3. Where in the workplace would you expect to find each document? In what way(s) does that influence how the document is written?

4. SAMPLE 1 has 7 sub-headings. Divide them into the following 3 sections. Write the step numbers in the spaces:

- a. General Information: _____
- b. Procedure: _____
- c. Additional Information: _____

5. SAMPLE 3 has 2 main sections. What sub-heading would you assign to each section?

6. Sometimes steps in instructions have sub-steps or multiple parts.

a. What are the 2 sub-steps in SAMPLE 1 sequence step 6?

b. What are the 2 sub-steps in SAMPLE 3 step 3?

7. What is being locked-out in each document?

8. Why is some of the information in Sample 3 written in capital letters?

9. Which document do you think is easier to read? What could you do to make the less-readable document easier to understand?

TOOL B**SAMPLE 1 - GENERAL LOCKOUT/TAGOUT PROCEDURE****Purpose**

This procedure establishes the minimum requirements for lockout of energy sources that could cause injury to personnel. All employees shall comply with the procedure.

Responsibility

The responsibility for seeing that this procedure is followed is binding upon all employees. All employees shall be instructed in the safety significance of the lockout procedure by (designated individual). Each new or transferred affected employee shall be instructed by (designated individuals) in the purpose and use of the lockout procedure.

Preparation for Lockout

Employees authorized to perform lockout shall be certain as to which switch, valve, or other energy isolating devices apply to the equipment being locked out. More than one energy source (electrical, mechanical, or others) may be involved. Any questionable identification of sources shall be cleared by the employees with their supervisors. Before lockout commences, job authorization should be obtained.

Sequence of Lockout Procedure

1. Notify all affected employees that a lockout is required and the reason therefor.
2. If the equipment is operating, shut it down by the normal stopping procedure (such as: depress stop button, open toggle switch).
3. Operate the switch, valve, or other energy isolating devices so that the energy source(s) (electrical, mechanical, hydraulic, other) is disconnected or isolated from the equipment.
4. Lockout energy isolating devices with an assigned individual lock.
5. Stored energy, such as that in capacitors, springs, elevated machine members, rotating fly wheels, hydraulic systems, and air, gas, steam or water pressure, must also be dissipated or restrained by methods such as grounding, repositioning, blocking, bleeding down.
6. After ensuring that no personnel are exposed and as a check on having disconnected the energy sources, operate the push button or other normal operating controls to make certain the equipment will not operate. CAUTION: Return operating controls to neutral position after the test.
7. The equipment is now locked out.

Restoring Equipment to Service

1. When the job is complete and equipment is ready for testing or normal service, check the equipment area to see that no one is exposed.
2. When equipment is clear, remove all locks. The energy isolating devices may be operated to restore energy to equipment.

Procedure Involving More Than One Person

In the preceding steps, if more than one individual is required to lock out equipment, each shall place his/her own personal lock on the energy isolating device(s). One designated individual of a work crew or a supervisor, with the knowledge of the crew, may lock out equipment for the whole crew. In such cases, it may be the responsibility of the individual to carry out all steps of the lockout procedure and inform the crew when it is safe to work on the equipment. Additionally, the designated individual shall not remove a crew lock until it has been verified that all individuals are clear.

Rules for Using Lockout Procedure

All equipment shall be locked out to protect against accidental or inadvertent operation when such operation could cause injury to personnel. Do not attempt to operate any switch, valve, or other energy isolating device bearing a lock.

SAMPLE 3 - EQUIPMENT LOCKOUT/TAGOUT PROCEDURE

	Equipment Number	Equipment Type	MCC *	Row	Bucket	Department
	0594 - 01	Motor	019	B	03	Board Plant
	Equipment Name					MCC Location
	Cutoff Knife Drive					Old Boiler Room
Potential Hazards:	<input checked="" type="checkbox"/> Electrical	<input type="checkbox"/> Pneumatic	<input type="checkbox"/> Mechanical	<input checked="" type="checkbox"/> Multiple Lockouts		
	<input type="checkbox"/> Hydraulic	<input type="checkbox"/> Chemical	<input type="checkbox"/> Combustibles	<input type="checkbox"/> Confined Space		
Methods of Neutralizing Energy:	<input type="checkbox"/> Relieve Pressure	<input type="checkbox"/> Block/Bleed	<input checked="" type="checkbox"/> Lockout/Tagout			
	<input type="checkbox"/> Disconnect Lines	<input type="checkbox"/> Set Fire Watch	<input type="checkbox"/> Confined Space Permit			
Permits Required:	<input type="checkbox"/> Safe Work	<input type="checkbox"/> Hot Work	<input type="checkbox"/> Line Blanking	<input type="checkbox"/> Confined Space		

Lockout Procedure:

1. Notify Production Supervisor and ALL affected personnel.
2. After completing Step 1, if running, shut down the equipment as trained. If you are not sure how, SEE YOUR SUPERVISOR.
3. "Lock" and "Tag" the equipment out at the "Knife Drives Cabinet", located across from the knife on the north wall, following the lockout procedure. CAUTION! THE COMPLETE LIVE ROLL SECTION MUST ALSO BE LOCKED OUT. REFER TO THE SPECIFIC LOCKOUT PROCEDURES FOR THAT EQUIPMENT. Test the equipment at the Knife control panel.
4. After ALL the previous steps have been completed, begin your work assignment.
5. After the completion of the work assignment, assure that the work area is clean.
6. Notify the Production Supervisor and/or ALL affected personnel that the equipment is operational and that removal of lock out will occur.
7. Remove ALL locks and tags following the lockout procedure.
8. When production is ready, verify that the equipment is operating correctly.
9. When Production is ready, verify that equipment is operating correctly.
10. Close out any applicable permit/s and return them to your supervisor.

* MCC means Motor Control Center

Review Date:
Revision Date:

Ref: Government of California. (n.d.). Sample 1 general lockout/tagout procedure. (pp. 1-2).

<https://www.dir.ca.gov/dosh/etools/08-003/P08-00301B.pdf>

HANDOUT: Navigating Codes (3 pages)
 Skill Builders: Key Words & Phrases, Skimming, Scanning, Navigating Regulations

IN THE WORKPLACE: The object of the Electrical Code is to establish safety standards for the installation and maintenance of electrical equipment in order to prevent fire and shock hazards, as well as ensure proper maintenance and operation. It is the responsibility of apprentices and journeypersons to be certain their work is consistent with the latest version of the Code.

Refer to the article **Tips for Navigating the Electrical Code** to complete the tasks and locate answers to the questions.

1. In what Part of the Code will you find information on the following?
 - a) Transmission circuit safety _____
 - b) Standards that cover all electrical installations _____
 - c) Residential inspections _____
 - d) Objective-based standards _____

2. Why are there no sections 11 or 13 in the Code Book?

3. How are changes from the previous versions of the Code indicated?

4. Complete the following table.

00-000	_____
_____	Subrule
_____	Item
(i)	Item
(A)	_____

5. Use the excerpt from the Code to answer the following.

- a) In what section is this rule? _____
- b) How many subrules are there? _____
- c) Which subrule contains items? _____
- d) Where can you find more information? _____
- e) Which subrule overrides subrule 1)? _____
- f) Which subrule is a change from the previous version? _____

12-510 Running of cable between boxes and fittings (see Appendices B and G)

Δ 1) Where the cable is run between boxes and fittings, it shall be supported by straps, Type 2S or 21S cable ties, or other devices located

- a) within 300 mm of every box or fitting; and
- b) at intervals of not more than 1.5 m throughout the run.

2) Cables run through holes in joists or studs shall be considered to be supported.

3) Notwithstanding Subrules 1) and 2), where the cable is run as concealed wiring such that it is impracticable to support it, and where metal sheeting or cladding, metal joists, metal top or bottom plates, or metal studs are not used, the cable shall be permitted to be fished and need not be supported between boxes and fittings.

Tips for Navigating the Electrical Code

Navigating the Code Book can be an intimidating exercise. These 4 tips can make it easier.

1. Understanding the Parts

The Canadian Electrical Code is published in several parts: Part I is the safety standard for electrical installations. Part II is a collection of individual standards for the evaluation of electrical equipment or installations. Part III is the safety standard for power distribution and transmission circuits. Part IV is a set of objective-based standards that may be used in certain industrial or institutional installations. Part VI establishes standards for the inspection of electrical installation in residential buildings.

2. Code Format

The Code Book is divided into numbered sections, each section covering a main component of electrical work. The general sections of the code book are 0, 2, 4, 6, 8, 10, 12, 14, 16 and 26. All other sections supplement or amend the general section. Rules found in the supplementary section overrule general section rules.

Even numbers have been used to identify sections and rules throughout the code with one exception being 38 which has odd numbered rules within it. The format was used to allow room for further expansion of new rules, as odd numbers.

3. Subdivision of Rules

The first two digits of the rule number represent the section number. Rules are divided as follows:

00-000	Rule
(1)	Subrule
(a)	Item
(i)	Item
(A)	Item

4. Changes to Rules

When a change in a rule has occurred from the previous version of the code book to the existing version identified by the delta symbol in the margin “ Δ ”. Remember, delta Δ means change.

Adapted from <https://www.electricalxamprepcanada.com/3-tips-on-using-the-canadian-electrical-code-book/> and https://en.wikipedia.org/wiki/Canadian_Electrical_Code

HANDOUT: Project Schedule Emails (3 pages)
Skill Builder: Key Words & Phrases, Skimming, Scanning

IN THE WORKPLACE: Email is used across the trades to discuss project details, apply for jobs, communicate project status, and even order parts. Being able to scan email quickly and accurately to locate key specifics is an increasingly important part of the job.

Refer to the **Project Schedule Emails** between Sam, the company owner, and Alex and Jane, project managers, to complete the tasks and locate the answers to the questions.

1. Using both emails, complete the calendar on the next page showing all of the tasks mentioned and which project each is associated with.

2. What and when are the tasks that Sam has to complete?

3. Sam needs to schedule a trip to Moose Jaw before the end of the month. The trip needs to be 3 consecutive days and the team there doesn't work weekends. When is the first available day that the trip can start?

May

Sun	Mon	Tue	Wed	Thu	Fri	Sat
						1
2	3	4	5	6	7	8
9	10	11	12	13	14	15
16	17	18	19	20	21	22
23	24	25	26	27	28	29
30	31					

Project Schedule Emails

Email 1:

From: Alex Water
<alex@samsco.com> Sent:
Thursday, May 6
Subject: Green Street update

Hi Sam,
Architect meeting confirmed for this Monday to review. I can handle it but you need to be in our office the next day to sign agreement. Building permit still on track for end of next week. Crew scheduled to take space the following Wed. Will be good if you were here for usual talk.

Alex

Email 2:

From: Jane Partner
<jane@samsco.com> Sent:
Thursday, May 6
Subject: Uptown Tower update

S:
Work crew orientation was yesterday and full on excavation starts today. Lumber scheduled for Monday 17 but I think it's too soon. Going to push it out 2 weeks. I called Tues and cancelled but they're going to want you to call to confirm that's the 2nd delay. They need the call 7 days minimum before the original delivery.
And, owner of office next door likes our work and wonders if you can stop in and see them when you're on site next Thurs? That's it.
J

HANDOUT: Safety Bulletin: HEO (3 pages)
Skill Builders: Key Words & Phrases

IN THE WORKPLACE: It is the shared responsibility of workers and employers to ensure that workplaces are free from accidents, injuries, illnesses or fatalities. Being aware of specific health risks common in specific occupations, helps catch potential issues before they arise.

Read the **For Workers** page of the safety bulletin written for Heavy Equipment Operators to complete the tasks and locate answers to the questions.

1. Complete the table to connect each possible hazard to a unique action that will minimize the risk and protect your health.

Possible Hazard	Minimize the Risk by...
1. When asbestos is present...	
2. When working with solvents...	
3. Before eating or drinking...	
4. When you see a hazard...	
5. When you don't know how to complete a task...	
6. Consult MSDS to learn about...	

2. Write an example for each type of hazard listed below.

a) Injection hazards

b) Biological hazards

c) Exhaust fumes

3. What are 3 hazards for HEOs specific to working outside?

4. What 4 groups of people share responsibility for preventing accidents and illnesses?

5. What is one thing the worker can do away from the workplace to reduce the spread of illness?

6. Identify 2 types of personal protection equipment (PPE) and when you should use each one.

FOR WORKERS



Tasks and possible hazards

All tasks

- ▶ **Hazardous materials from industrial worksites** (pulp and paper, refineries, chemical plants, glass plants, factories, cement plants, foundries/smelters, power plants, nuclear plants)
- ▶ **Awkward postures and vibration** when mounting or dismantling equipment, **vibration and hazardous noise** while using heavy equipment
- ▶ **Asbestos** (could be part of the equipment—in old brake pads—or in building materials)
- ▶ **Dust and insulation fibres** on construction sites
- ▶ **Bearing greases, lubricants, cleaning solutions, machine and cutting fluids**
- ▶ **Solvents, adhesives, and epoxies**
- ▶ **Biological hazards** in soil, industrial plants or on equipment
- ▶ **West Nile Virus** from mosquito bites
- ▶ **Ultraviolet light** from the sun
- ▶ **Exhaust fumes** from gas- or diesel-powered equipment
- ▶ **Injection hazards** from compressed air or hydraulic hose failure
- ▶ **Radio frequency (RF) energy** from base station antennas such as cell towers
- ▶ **Hazardous noise** from surrounding construction activities.

Other hoisting devices

- ▶ **Extreme temperatures** in cold or hot environments
- ▶ **Dust** on construction sites.

How to protect your health

- ▶ Ask your supervisor or employer for safe work **instructions** and training.
- ▶ Consult industrial clients on site-specific health and safety **procedures**.
- ▶ Ask about any hazardous materials or unknown chemicals when **entering** an industrial site for work.
- ▶ Ensure proper **ventilation**.
- ▶ Wear a proper **respirator** when
 - you suspect asbestos may be a hazard
 - working in dusty atmospheres
 - welding
 - using solvents, adhesives, or other hazardous substances
 - using metalworking fluids (cutting oils).
- ▶ Wear gloves, coveralls or welding jackets, or use barrier creams to protect the **skin**.
- ▶ Consult material safety data sheets (**MSDSs**) for information about hazardous chemicals used at work, and obey workplace health and safety rules.
- ▶ **Never eat, drink, smoke, or chew gum** in areas contaminated with asbestos, lead, or toxic chemicals.
- ▶ Wash or wipe **hands** clean before eating, drinking, and smoking, and always clean up and change out of contaminated **clothing** before going home at the end of the shift.
- ▶ Wash work clothes **separately** from casual and other family members' clothes.
- ▶ **Report** hazards to your employer.

Workers who are without symptoms and who have been exposed to asbestos may participate in a research study at Princess Margaret Hospital by volunteering to be screened for mesothelioma/asbestos.

Phone: 416-340-5686 Fax: 416-340-4964

For more information about health and safety in your job, contact your union or

Infrastructure Health & Safety Association: 1-800-263-5024, www.ihsa.ca

Ontario Ministry of Labour: 1-877-202-0008, www.labour.gov.on.ca

Workplace Safety and Insurance Board: 1-800-387-5540, www.wsib.on.ca



HANDOUT: Starting Your Own Business (4 pages)

Skill Builders: Key Words & Phrases, Skimming, Scanning

IN THE WORKPLACE: For many apprentices, one of the appeals of having a trade is the possibility of someday starting your own business. Being your own boss comes with a lot of freedom but also a great deal of responsibility

Refer to the article **5 Must-Dos For Running Your Own Business** to complete the tasks and locate answers to the questions. Being able to predict content from titles and sub-titles in a document is an effective strategy to make it easier to understand the content and read faster and more efficiently.

1. **Before** reading the article, and just looking at the title, list 4 things you think are most important for starting your own business.

2. **Before** reading the article, review the list of sub-titles below and write one thing you would expect to find included in each section. **Then** read the article and check your predictions to see if they are the same as the information included in the article.

a) Converting Leads to Sales

b) Fire Yourself

c) Calculating Overhead

d) Don't Get Complacent

3. Locate each of the following in the article and write another word (or phrase) that means the same thing.

a. Overhead _____

b. Lead _____

c. Break even _____

d. Grasp _____

e. Asset _____

4. What 4 factors need to be included when calculating overhead?

5. What are 3 examples of administrative components?

6. What are 4 examples of ways to thank customers for their business?

7. Draw a diagram to show the relationships between reputation, good work, and trust.

5 Must-Dos For Running Your Own Business

As a tradesperson, some of the main factors necessary for running a successful business are the same for just about any other type of company: Provide a service your customers cannot do without, and do it so well that yours will be the first name they think of when they have a construction, plumbing, electrical or general repair issue. However, you obviously have a lot of competition out there, so how do you separate yourself? These are just a few of the ways you can build a sustainable business.

Converting Leads to Sales

Most new companies have a goal of breaking even within a year or two, but there is nothing wrong with turning a profit sooner. There are a few strategies that can help you get to that point. For example, provide rewards for customer referrals, or offer discounts to return customers. Offer follow-up services to make sure your customers are still happy with your work. Consider establishing a frequent buyer program to reward loyal customers and keep them coming back.

If you do not have a website, it is time to embrace the Internet and all that it can provide. A well-built site can drive a steady stream of customers to your business. There are several tools – many of them free – that can help you establish an effective online presence that will take very little day-to-day effort on your part. Social media is the word of mouth of the 21st Century.

Fire Yourself

As great a tradesperson as you may be, there is only one of you. If your goal is to build the most successful business you can, that will mean taking on far more jobs than you could ever complete on your own. You will very likely need to fire yourself as a worker and hire yourself as a business manager. You will need a solid grasp of the administrative components of your company, such as personnel, marketing and finances. There is no way you will be able to focus on those areas if you are still making service calls every day.

Calculating Overhead

One of the main stumbling blocks to building a successful business is not having a clear understanding of your costs. If you do not have the most accurate picture possible of the expenses associated with providing your services, you will have an extremely difficult time correctly setting up your pricing structure. You need to take a close look at all of your costs, including labour, equipment (don't forget to take factors such as depreciation of vehicles into consideration), marketing and materials. You also need to have an idea of how many jobs you need to earn in order to start making a profit.

Don't Get Complacent

It is natural for some people to get to a certain level in their business and then lose the drive that got them to that level in the first place. If you want to build the most successful business you can, complacency can never be allowed. Your reputation is your most important asset; you would be shocked at how quickly your business could fail if you allow a lackadaisical attitude to set in and your work begins to suffer as a result. In order to increase profitability, you need to continually improve wherever you can. The stronger your reputation, the more trust you build among your customers. The more trust you build, the more work will come your way. As long as you remain passionate about what you do every day, your chances of success are very good.

Ref: Mascari, T. (September 21, 2015). 5 must-do's for running a successful plumbing business. (Blog post). <https://porch.com/pro/blog/2015/09/5-must-dos-for-running-a-successful-plumbing-business/>

HANDOUT: Step by Step Instructions: Millwright (3 pages)
Skill Builders: Scanning, Percentages, Decimals & Fractions

IN THE WORKPLACE: Following detailed step by step instructions to build structures or install and operate machinery is part of most tradesperson's work. Errors in sequencing steps or skipping them altogether can result in significant losses to the company in lost time and wasted materials.

Read **Step by Step Instructions** to locate answers to the questions. Write the answers in the space provided.

1. What is the process being described?

2. Divide the steps of the process into the following 3 phases. Write the step numbers in the spaces:

a. Safety: _____

b. Preparation: _____

c. Procedure: _____

3. Sometimes steps in instructions have sub-steps or multiple parts.

- a. Which steps have sub-steps that must be performed to successfully complete the procedure? List them.

- b. How many sub-steps are in Step 10? List them.

4. Which steps are performed before the wheel touches the part?

5. Which steps must be completed before setting the grinding depth?

6. What parts are magnetic?

7. Why is some information in steps 1,9, and 14 written in brackets? How is it different from the rest of the instructions?

8. Write the following decimals as percentages and as fractions:

a. 0.0005 _____

b. 0.001 _____

c. 0.0002 _____

9. The measurements given are very precise. Calculate the difference in size between 0.0005" and 0.0001" and show your answer as a fraction.

STEP BY STEP INSTRUCTIONS GRINDING PROCEDURE FOR METAL STOCK

1. Ensure the proper wheel for the stock is being used (there are different grinding wheels for aluminum, stainless steel, and titanium), the wheel is not defective and is properly dressed for the grinding application.
2. Clean the bed before placing the workpiece onto it. This will prevent interference with the magnetic chuck.
3. Place magnetic parallels around the workpiece to ensure the workpiece does not shift during grinding. Turn the magnetic chuck on to secure the pieces onto the bed.
4. Adjust the bed and saddle position to center the stock below the wheel.
5. Lower the wheel an inch above the workpiece.
6. Take a piece of paper and place it between the wheel and the stock. Move the paper back and forth while simultaneously lowering the wheel until the paper is no longer able to move to zero the z-axis. Zero the z-axis of the workpiece by setting the dial on downfeed handwheel to 0 inches.
7. Lock the table Longitudinal stroke setting block so that there is about an inch of overtravel at each end of the table stroke.
8. Adjust the table position so the wheel sits about an inch to the right of the workpiece.
9. Lower the wheel to the desired depth of grinding (preferably 0.0005"- 0.0001" per pass). There should be a maximum downfeed of 0.001 inch per pass.
10. Ensure the wheel is not in contact with the workpiece before turning the main power on. Press the green button to turn the spindle on and turn the coolant switch on.
11. Grind the stock by making passes left to right along the x-axis.
12. Once the first strip of the workpiece has been sufficiently ground, turn the y-axis handwheel half a turn clockwise.
13. Grind another strip of the workpiece from left to right along the x-axis.
14. Repeat until the workpiece is fully ground, then repeat all the previous steps for the other side (take a piece of paper and place it between the magnetic chuck and stock to protect the finish).
15. When finished, elevate the wheel then clean the machine and the surrounding area.

Ref: Virasak, L. (2019). Chapter 5 Surface Grinding. In Manufacturing processes 4-5. (pp. 133-143). Retrieved from: <https://openoregon.pressbooks.pub/manufacturingprocesses45/chapter/chapter-5-surface-grinder/>. This work has been adapted. [Manufacturing Processes 4-5](#) by LamNgeun Virasak is licensed under a [Creative Commons Attribution 4.0 International License](#), except where otherwise noted.



Reading Text Answer Keys



ANSWER KEY: Efficient Reading: Dislocations
Skill Builders: Key Words & Phrases, Skimming, Scanning

Answers to the questions will vary according to the interests and any previous knowledge of the individuals reading the texts.

There are 5 activities designed to improve efficient reading. The topics are:

- Dislocations
- Build a Drone
- Solar Power
- Sports Story
- White Fang (fiction)

Instructors are encouraged to use their own authentic documents to replicate the activity and provide additional practice. Consider trade journals, magazines, and your local newspaper in print and online format.

ANSWER KEY: Efficient Reading: Building a Drone
Skill Builders: Key Words & Phrases, Skimming,

Answers to the questions will vary according to the interests and any previous knowledge of the individuals reading the texts.

There are 5 activities designed to improve efficient reading. The topics are:

- Dislocations
- Building a Drone
- Solar Power
- Sports Story
- White Fang (fiction)

Instructors are encouraged to use their own authentic documents to replicate the activity and provide additional practice. Consider trade journals, magazines, and your local newspaper in print and online format.

ANSWER KEY: Efficient Reading: Solar Power
Skill Builders: Key Words & Phrases, Skimming, Scanning

Answers to the questions will vary according to the interests and any previous knowledge of the individuals reading the texts.

There are 5 activities designed to improve efficient reading. The topics are:

- Dislocations
- Build a Drone
- Solar Power
- Sports Story
- White Fang (fiction)

Instructors are encouraged to use their own authentic documents to replicate the activity and provide additional practice. Consider trade journals, magazines, and your local newspaper in print and online format.

ANSWER KEY: Efficient Reading: Sports Story
Skill Builders: Key Words & Phrases, Skimming, Scanning

Answers to the questions will vary according to the interests and any previous knowledge of the individuals reading the texts.

There are 5 activities designed to improve efficient reading. The topics are:

- Dislocations
- Building a Drone
- Solar Power
- Sports Story
- White Fang (fiction)

Instructors are encouraged to use their own authentic documents to replicate the activity and provide additional practice. Consider trade journals, magazines, and your local newspaper in print and online format.

ANSWER KEY: Efficient Reading: : White Fang (Fiction)
Skill Builders: Key Words & Phrases, Skimming, Scanning

Answers to the questions will vary according to the interests and any previous knowledge of the individuals reading the texts.

There are 5 activities designed to improve efficient reading. The topics are:

- Dislocations
- Build a Drone
- Solar Power
- Sports Story
- White Fang (fiction)

Instructors are encouraged to use their own authentic documents to replicate the activity and provide additional practice. Consider trade journals, magazines, and your local newspaper in print and online format.

ANSWER KEY: Changes in the Electrical Code

Skill Builders: Key Words & Phrases, Skimming, Scanning

1. What do each of the following acronyms stand for?
 - a) EVSE: **electric vehicle supply equipment**
 - b) GFCI: **ground fault circuit interrupter**
 - c) LED: **light emitting diode**
 - d) TR: **tamper resistant**

2. What does the term “wet areas” refer to?
The area in the vicinity of sinks, showers or tubs

3. What voltage LEDs are affected by the 2018 change?
LEDs that are more than 150 V

4. What new rules and subrules also refer to the provision of power related to electric vehicles?
Rule 8-500 and Subrules 8-106(11) and (12)

5. When was the previous version to the 2018 Code published? Assuming the same number of years between revisions, when will the next version be published? **Previous was 2015. Next will be 2021. Every 3 years.**

6. Changes to the Code typically reflect changes in consumer behaviour and expectations. Select 2 of the changes and in your own words describe why you think the changes were made. **Answers will vary but must be logical. Possible answers include the following.**
 1. Disconnecting means for LED luminaires
Expanded use and available variety of LEDs mean they’ve become the new standard for consumers and are much more common.

 2. Tamper resistant (TR) receptacles
Modern approaches to parenting means small children are present in more types of spaces rather than kept at home. Hotels and schools may also be concerned about liability if there is an accident.

 3. Increased GFCI protection for wet areas
Bathrooms have become much larger as consumers want a spa experience at home. Things like heated floors mean greater demand on the electrical system.

 4. Electric vehicle energy management system
EVs are becoming a more affordable reality for consumers and more want to be able to charge them without extensive changes to residential electrical system. This must be balanced with safety.

ANSWER KEY: Demand for Skilled Trades
Skill Builders: Key Words & Phrases, Skimming, Scanning

1. **Before** reading the article, and just from looking at the title, list 3 topics you expect to find mentioned in the article. **Answers will vary, but could include: how many unfilled skilled trades jobs there are in Canada; reasons why the skilled trades can't find enough workers; which skilled trades have the most trouble finding workers.**
2. Who authored the report referred to? **ManpowerGroup Canada**
3. How many employers participated in the survey? **Nearly 2000**
4. According to the article, what is a large organization? **250-plus employees**
5. A "gap" is the distance between 2 things or sides. What are the 2 sides of the skillsgap? **Gap is between skills job seekers have and skills employers need.**
6. Articles often use a lot of "jargon" or words that are specific to the topic being discussed. In your own words, write a definition for each of the following jargon words used in the human resources sector: **Answers will vary. Suggestions include:**
 - a) Boomerang retirees: **people coming back to work after retiring**
 - b) Upskilling: **getting more training in same occupation**
 - c) Reskilling: **getting training in a new occupation**
 - d) Learning platform: **way to get online training**
 - e) Adjacent skills: **skills that can be transferred to new occupation**
 - f) Skilled trade: **occupations that require post-secondary**
7. Complete the following table.

%	Of employers...
28%	... are changing their existing work models
41%	... can't find skilled people they need
68%	... are investing in learning platforms
58%	... in large organizations report talent shortages
56%	... are looking at different talent pools

8. Identify 2 things that employers are doing to attract new employees. **Any 2 of offering upskilling, offering reskilling, offering online learning, changing work models, offering flexible work options.**
9. The article focuses on what employers can do to fill jobs. What is an example of something a worker can do? **Answers will vary.**
10. Now that you've read the article, look back at your prediction in Question 1. Did your predictions match the content of the article? What do you think would be a different good title for the article? **Answers will vary.**

ANSWER KEY: Finding Information in Codes: Building
Skill Builders: Key Words & Phrases, Skimming, Scanning, Navigating Regulations

- Using the following structure, complete the table below using the information in the excerpt. Locate and use the first example that allows you to complete every line in the structure. The first line is done for you.

Division	B: Acceptable Solutions
Part	3: fire protection, occupant safety and accessibility
Section	3.8 building requirements for persons with disabilities
Sub-section	3.8.2 classification requirements
Article	3.8.2.1 application and exemptions
Sentence	3.8.2.1 (2) This section does not apply to...
Clause	3.8.2.1 (2) (a) the storey next above or below...
Subclause	3.8.2.1 (2) (a) (i) is less than 600 m² in floor area

- What are the 3 main categories of information sub-section 3.8.2?
**Application and Exemptions Design
Requirements Specific
Requirements**
- Angles brackets < > are used to indicate changes between the current and previous versions of the Code. How many changes are indicated in 3.8.2.1 and what do they refer to?
**One set of brackets,
three types of changes
All are rules around exempt buildings**
- What is the rule number that governs openings through firewalls?
3.8.1.2
- Under what circumstances must at least 1 universal toilet room be provided?
where the *occupant load of the building or occupancy exceeds 150*
- What size units does subsection 3.8.2 apply to?
**more than 600 m² in *floor area* to the story next above or below accessible storey
Group E shops and stores with a total retail floor space of more than 50 m²**
- Where can you find more information on Group C apartment buildings?
Article 3.8.2.27.,
- How many specific requirements are identified in 3.8.2.3(1)?
5

9. What 2 parking options are permitted? Provide the full rule number where you found the answer.

a) access from the street to at least one main entrance conforming to Article 3.8.3.5.,

b) where off-street parking is provided for *persons with disabilities*, **<access> from the parking area to an entrance conforming to Article 3.8.3.5. **<that>** serves the parking area unless the entrance in Clause (a) is located so as to conveniently serve both the parking area and the *street*,**

3.8.2.3.1(a) and (b)

10. Does this excerpt from the building code apply to new construction only? Provide the full rule number where you found the answer.

NO

3.8.1.1.3

3) Access shall be provided to alterations, additions and changes in occupancy to the extent required in Subsection 3.8.4.

ANSWER KEY: Finding Information in the Codes: Electrical

Skill Builders: Key Words & Phrases, Skimming, Scanning, Navigating Regulations

1. What are the 4 main categories of information in Section 86?
Scope, General, Equipment, Control and protection
2. What are the rule and/or subrule numbers of information that is new in this version of the Code?
86-100 (EVSE information) and 86-300 (2)
3. Complete the rule number for control and protection: **86-300**
4. Complete the rule number for voltages: **86-102**
5. Complete the rule number for connected loads: **86-302**
6. What information must be included on warning signs?
That the equipment must not be operated without sufficient ventilation as recommended by the manufacturer's installation instructions.
7. What vehicle types are not covered by Section 86?
Off-road electric vehicles
8. What is the maximum voltage for vehicles covered under Section 86? **750 V**
9. Where can you find more information on branch circuits? **Appendix D**
10. What 3 conditions must be met for the vehicle supply equipment to be considered to have a separate disconnecting?
That the disconnecting is 1) on the supply side of the point of connection, 2) located within sight of and accessible to the EVSE, and 3) capable of being locked in the open position.
11. What are 3 sources of electrical current to vehicle motors?
Fuel cell, photovoltaic array, rechargeable energy storage system (such as a battery or capacitor)
12. Where can you find more information on the max connected load? **Rule 8-104**
13. What provision must be made for a charging receptacle installed outside?
That it shall be protected with a GFCI of the Class A type.
14. When is it permissible to supply equipment from a branch circuit that is supplying another load as well? Provide the full rule number where you found the answer. **Provided that an EVEM system is installed in accordance with Subrule 8-106 (11) or (12). Answer found in 86-300 (2).**

ANSWER KEY: Finding Information in Codes: Plumbing

Skill Builders: Key Words & Phrases, Skimming, Scanning, Navigating Regulations

- Using the following structure, complete the table below using the information in the excerpt. Locate and use the first example that allows you to complete every line in the structure. The first line is done for you.

Division	B: Acceptable Solutions
Part	2 Plumbing Systems
Section	2.5 Venting Systems
Sub-section	2.5.1 Venting for Traps
Article	2.5.1.1. Venting for Traps
Sentence	2.5.1.1 (4) A trap need not be protected by a vent pipe
Clause	2.5.1.1 (4) (a) where it serves
Subclause	2.5.1.1 (4) (a) (i) a subsoil drainage pipe, or

- What are the 3 main categories of information in section 2.5? **Venting for traps, wet venting, circuit venting.**
- Angles brackets < > are used to indicate changes between the current and previous versions of the Code. How many changes are indicated in 2.5.2 and what do they refer to? **One change. Refers to the hydraulic load of separately vented fixtures.**
- What is the full rule number that governs outlet pipes of less than 2 inches? **2.5.3.1(2)**
- Under what circumstances does a trap not need to be protected by a vent pipe? **When it serves a subsoil drainage pipe OR a storm drainage system, OR where it is part of an indirect drainage system.**
- What size offset is permitted for pipes larger than 2 inches? **Less than 2.5 m**
- Where can you find more information on additional protections for drainage systems? **Subsection 2.5.4**
- How many clauses are identified in 2.5.2.1? **11 (a through k)**
- What is the maximum number of fixtures that can be connected to a combined relief and circuit vent? Provide the full rule number where you found the answer. **Eight. 2.5.3.1(4)**
- What 3 rules refer to emergency floor drains? **2.5.2.1(1) (e), 2.5.2.1 (1) (j) and 2.5.1.1. (3) (While the last does not contain the word "emergency" it is referenced in the previous 2 and therefore must be considered.)**

ANSWER KEY: Occupational Health and Safety Regulations
Skill Builders: Key Words & Phrases, Navigating Regulations

1. What is the title of section 2.3? **Doors**
2. In your own words, what is section 2.3 about? **Answers will vary. Suggested answer: Rules that govern how all doors (including gates) should be installed and how they will function, as well as any signage that needs to be posted near doors.**
3. Who is this regulation written for? **Anyone responsible for planning or installing doors, such as construction workers and architects, as well as workers responsible for ongoing safety in and around doors.**
4. As a result of section 2.3 (1), what is the appearance of most public swinging doors? **They are see-through.**
5. If a gate or door opens into a hallway, what document would tell you how wide the hallway needs to be? **The National Building Code.**
6. Underline 3 terms that you think should be defined in the *Interpretations* section at the beginning of Part II. Google the definition for each and write them below. **Answers will vary.**
7. How is section 2.12 formatted to make it easier to read?
Answers will vary but may include: Information is broken into small "chunks". The topic of each chunk is indicated at the start of each. Uses numbered and ordered lists and bold font used to highlight numbers and letters.
8. How far apart do supporting posts need to be spaced? **A maximum of 3 metres apart (measured from the centre of each post)**
9. How tall should the guardrail be? **Answer: Between 900 – 1100 mm**
10. Label the picture consistent with parts a), b) and c) of 2.12 (1). **Suggestion answer below.**

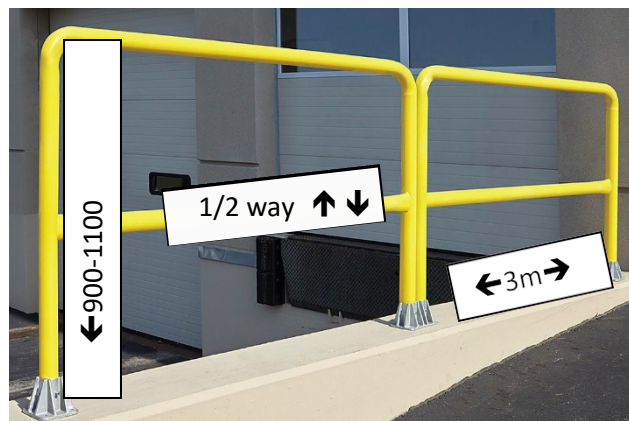

ANSWER KEY: Heat Stress Safety Bulletin Skill
 Builders: Key Words & Phrases, Skimming, Scanning

1. In your own words, what causes heat stress? **Answers will vary but should include reference to the fact that heat stress happens when the body is unable to cool itself.**
2. What types of heat-related illnesses do not usually require medical attention?
Heat rash and heat cramps (if treated as suggested).
3. In what cases can heat stress cause death? **Untreated heat exhaustion and heat stroke.**
4. Heat **stress** happens when the body loses too much water. Heat **rash** may appear on the body. Heat **cramps** are felt in the body. One sign of heat **exhaustion** is nausea. The most serious heat-related **illness** is heat **stroke**.
5. Changes in heart rate can indicate heat stress. What could the following indicate?
 - a. Fast heart rate: **heat stroke**
 - b. Slow heart rate: **fainting**
6. Whose responsibility are each of the following? Put an X in the column.

Prevention Tip	Workers	Managers
1. Wear light fitting clothing	X	
2. Schedule hot jobs in morning		X
3. Avoid coffee	X	
4. Monitor personal health	X	
5. Provide breaks		X
6. Drink water	X	

7. Taylor has been working outside all summer. Last night, several of the crew went out for beers after work. This morning Taylor has had a couple of iced-coffee to stay cool and alert but now suddenly feels cramping in both legs.
 - a. What do you think the problem is? **Heat cramps**
 - b. What are 2 things that can be done to treat the problem?
Any 2 of rest in a cool place, remove or loosen clothing, drink cool water or a sports drink containing electrolytes, stretch and massage muscles.
 - c. What are 2 things Taylor could have done to prevent the problem?
Avoid drinking alcohol the night before. Avoid coffee.

ANSWER KEY: Lockout Procedure
Skill Builders: Key Words & Phrases, Skimming, Scanning

1. Who is the intended audience for SAMPLE 1? **All employees.**
2. Who is the intended audience for SAMPLE 3? **Workers performing maintenance or related work assignments on the Cutoff Knife Drive.**
3. Where in the workplace would you expect to find each document? In what way(s) does that influence how the document is written? **Sample 1: in a safety manual. Sample 3: displayed by the Cutoff Knife Drive. General information in a safety manual can be more detailed and include the background and rationale for the procedure. Information located beside a specific machine should only refer to the procedure for that machine so workers can complete the procedure quickly and efficiently.**
4. SAMPLE 1 has 7 sub-headings. Divide them into the following 3 sections. Write the step numbers in the spaces:
 - a. General Information: **1, 2, 3**
 - b. Procedure: **4, 5**
 - c. Additional Information: **6, 7**
5. SAMPLE 3 has 2 main sections. What sub-heading would you assign to each section?
1. Hazard and Lockout Assessment 2. Procedure.
6. Sometimes steps in instructions have sub-steps or multiple parts.
 - a. What are the 2 sub-steps in SAMPLE 1 sequence step 6? **1. Check that no personnel are exposed, 2. Operate the push button (or other normal operating control)**
 - b. What are the 2 sub-steps in SAMPLE 3 step 3? **1. Lock and tag the equipment. 2. Test the equipment at the Knife control panel.**
7. What is being locked-out in each document? **SAMPLE 1: Any energy source (electrical, mechanical or others). SAMPLE 3: Cutoff Knife Drive.**
8. Why is some of the information in Sample 3 written in capital letters? **It is a safety warning.**
9. Which document do you think is easier to read? What could you do to make the less-readable document easier to understand? **Answers will vary. Possible suggestions are: add /number sub-headings, use colour, add diagrams, edit text so instructions are shorter, etc.**

ANSWER KEY: Navigating Codes

Skill Builders: Key Words & Phrases, Skimming, Scanning, Navigating Regulations

1. In what Part of the Code will you find information on the following?
 - a) Transmission circuit safety: **Part III**
 - b) Standards that cover all electrical installations: **Part I**
 - c) Residential inspections: **Part VI**
 - d) Objective-based standards: **Part IV**

2. Why are there no sections 11 or 13 in the Code Book?
Eleven and 13 are odd numbers and there are no odd numbers to allow for further expansion of rules as odd numbers.

3. How are changes from the previous versions of the Code indicated?
With the delta symbol Δ

4. Complete the following table.

00-000	Rule
(1)	Subrule
(a)	Item
(i)	Item
(A)	Item

5. Use the excerpt from the Code to answer the following.
 - a) In what section is this rule? **Section 12**
 - b) How many subrules are there? **3**
 - c) Which subrule contains items? **Subrule 1**
 - d) Where can you find more information? **Appendices B and G**
 - e) Which subrule overrides subrule 1)? **Subrule 3**
 - f) Which subrule is a change from the previous version? **Subrule 1**

12-510 Running of cable between boxes and fittings (see Appendices B and G)

Δ 1) Where the cable is run between boxes and fittings, it shall be supported by straps, Type 2S or 21S cable ties, or other devices located

- a) within 300 mm of every box or fitting; and
- b) at intervals of not more than 1.5 m throughout the run.

2) Cables run through holes in joists or studs shall be considered to be supported.

3) Notwithstanding Subrules 1) and 2), where the cable is run as concealed wiring such that it is impracticable to support it, and where metal sheeting or cladding, metal joists, metal top or bottom plates, or metal studs are not used, the cable shall be permitted to be fished and need not be supported between boxes and fittings.

ANSWER KEY: Project Schedule Emails
Skill Builder: Key Words & Phrases, Skimming, Scanning

1. See below.

Sun	Mon	Tue	Wed	Thu	Fri	Sat
						1
2	3	4 UT lumber cancelled	5 UT orientation	6 UT excavation	7	8
9	10 GS architect Meeting Last day to call UT lumber	11 Sign GS agreement	12	13 See owner next door at UT site	14 GS building permit	15
16	17 UT lumber to arrive	18	19 GS crew starts. Give talk	20	21	22
23	24	25	26	27	28	29
30	31 New UT lumber date					

2. What, where and when are the tasks that Sam has to complete?
 - **Sign GS agreement. Tues May 11 in Sam's office**
 - **Talk to GS crew. Wed May 19 on GS site**
 - **Call re lumber. No later than May 10**
 - **Meet potential client. Thurs May 13 at UT site**

3. Sam needs to schedule a trip to Moose Jaw before the end of the month. The trip needs to be 3 consecutive days and the team there doesn't work weekends. When is the first available day that the trip can start? **Monday May 24**

ANSWER KEY: Safety Bulletin: HEO
Skill Builders: Key Words & Phrases

- Complete the table to connect each possible hazard to a unique action that will minimize the risk and protect your health.

Possible Hazard	Minimize the Risk by...
1. When asbestos is present...	Wear a proper respirator
2. When working with solvents...	Wear gloves (PPE)
3. Before eating or drinking...	Wash your hands
4. When you see a hazard...	Report it to your employer
5. When you don't know how to complete a task...	Ask for safe work instructions and training
6. Consult MSDS to learn about...	Hazardous chemicals used at work

- Write an example for each type of hazard listed below.
 - Injection hazards: **compressed air or hydraulic hose failure**
 - Biological hazards: **in soil, industrial plants or on equipment**
 - Exhaust fumes: **gas or diesel powered equipment**
- What are 3 hazards for HEO specific to working outside?
Any 3 of: West Nile Virus, ultraviolet light, biological hazards in soil, or extreme temperatures.
- What 4 groups of people share responsibility for preventing accidents and illnesses?
Workers, supervisors, employers, industrial clients
- What is one thing the worker can do away from the workplace to reduce the spread of illness?
Wash work clothes separately from casual and other family members' clothes
- Identify 2 types of personal protection equipment (PPE) and when you should use each one.
 - Respirator when working with asbestos, dust, and solvents/adhesives OR when welding and using metal working fluids.**
 - Gloves, coveralls OR welding jacket when skin protection is required.**

ANSWER KEY: Starting Your Own Business

Skill Builders: Key Words & Phrases, Skimming, Scanning

1. Answers will vary but should be logical.
2. Answers will vary but should be logical.
3. Answers will vary. Suggestions include:
 - a. Overhead: **total costs of operating a business before profit**
 - b. Lead: **a possible customer (not to be in charge or a metal or a conductor)**
 - c. Break even: **the point where income equals costs**
 - d. Grasp: **understanding (not to grab with the hand)**
 - e. Asset: **a useful or valuable thing**
4. What 4 factors need to be included when calculating overhead?
Labour, equipment, marketing and materials.
5. What are 3 examples of administrative components?
Personnel, marketing and finances.
6. What are 4 examples of ways to thank customers for their business?
Rewards for referrals, discounts to return customers, follow-up services, and frequent buyer program.
7. Draw a diagram to show the relationships between reputation, good work, and trust.
Answers will vary but should indicate reputation → trust → good work. May also include the idea of an ongoing cycle.

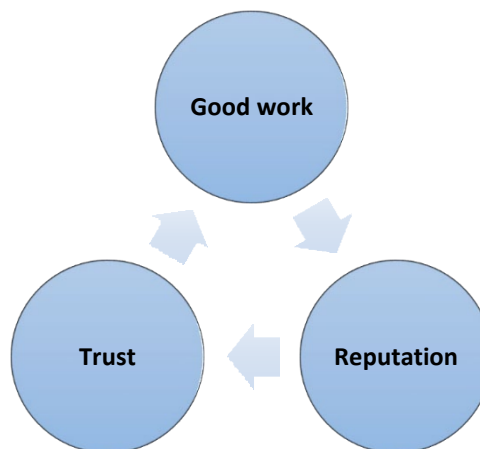

ANSWER KEY: Step by Step Instructions: Millwright

Skill Builders: Scanning, Percentages, Decimals & Fractions

1. What is the process being described? **Grinding procedure for metal stock**
2. Divide the steps of the process into the following 3 phases. Write the step numbers in the spaces: **Note: answers may differ and may be considered correct if the pre/apprentice can logically justify them.**
 - a. Safety: **1 & 15**
 - b. Preparation: **2-10**
 - c. Procedure: **11-14**
3. Sometimes steps in instructions have sub-steps or multiple parts.
 - a. Which steps have sub-steps that must be performed to successfully complete the procedure? List them. **Steps 1, 3, 6, 10 and 15. All other steps provide additional information for performing a single step in the procedure.**
 - b. How many sub-steps are in Step 10? List them. **There are 3 steps.**
 1. **Ensure the wheel is not in contact with the workpiece before turning the main power on.**
 2. **Press the green button to turn the spindle on.**
 3. **Turn the coolant switch on.**
4. Which step are performed before the wheel touches the part? **Steps 1-10**
5. Which steps must be completed before setting the grinding depth? **Steps 1- 8**
6. What parts are magnetic? **Chuck and parallels.**
7. Why is some information in steps 1, 9 and 14 written in brackets? How is it different from the rest of the instructions? **The information in the brackets are tips for how to complete the steps. The rest of the information are the basic directions.**
8. Write the following decimals as percentages and as fractions:
 - a. $0.0005 = 0.05\%$ and $5/10,000$
 - b. $0.001 = 0.1\%$ and $1/1,000$
 - c. $0.0002 = 0.02\%$ and $2/10,000$
9. The measurements given are very precise. Calculate the difference in size between $0.0005''$ and $0.0001''$ and show your answer as a fraction. **$4/10,000$ ($.0004$)**



Document Use



Handouts: Apprenticeship Completion (2 pages)
Skill Builders: Key Words & Phrases, Flowcharts

IN THE WORKPLACE: Apprenticeship completion is a serious issue. While the experience of every apprentice is unique, recognizing frequently cited barriers to completion and preparing for how to address them if they arise, is a key to attaining certification.

Refer to the **Apprenticeship Status** chart and graph to locate the answers to the following questions.

1. If the total number of survey respondents was 28,469, how many people discontinued their program during 2011- 2013?

2. What percentage of those apprentices who discontinued their program went on to complete in 2015? How many people is that?

3. What period of time has elapsed between the two pie charts?

4. What data is shown on each of the X and Y axes in the bar chart?

5. The values in the bar chart do not add up to 100 percent. What is the approximate percentage of missing values in the bar graph? Why are the missing values excluded from the bar graph?

6. Redraw the bar graph as a pie chart. Represent all reasons of more than 5% by their own section. Represent all other reasons including any missing values as a single section labelled "other". Label the chart section including text and percentages. Use whole numbers for all values.

Apprenticeship Status

Apprentice status (2011 to 2013) and apprentice status of discontinuers in 2015, Canada

Apprentice status (2011 to 2013)

Apprentice status of discontinuers (2015)

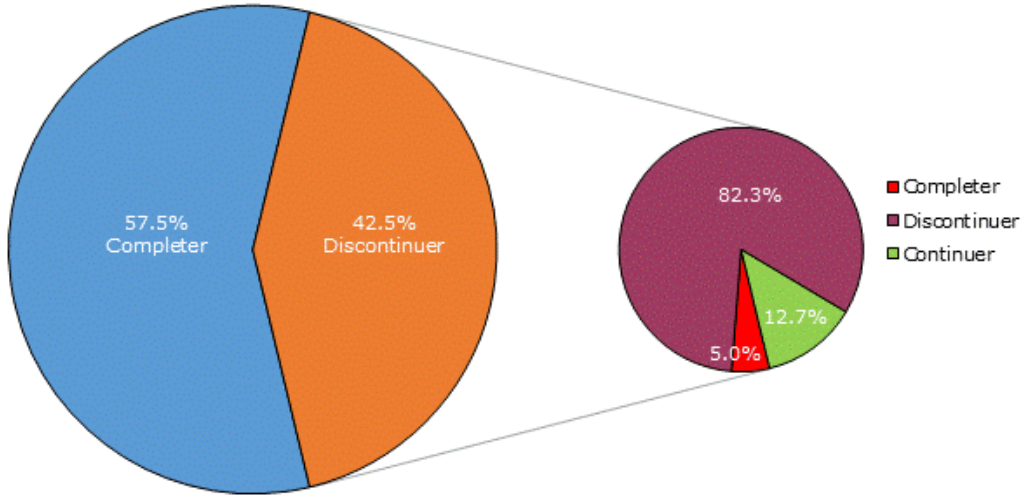

Source: Statistics Canada, National Apprenticeship Survey (NAS), 2015.

Main reason reported by discontinuers for not completing their apprenticeship, Canada

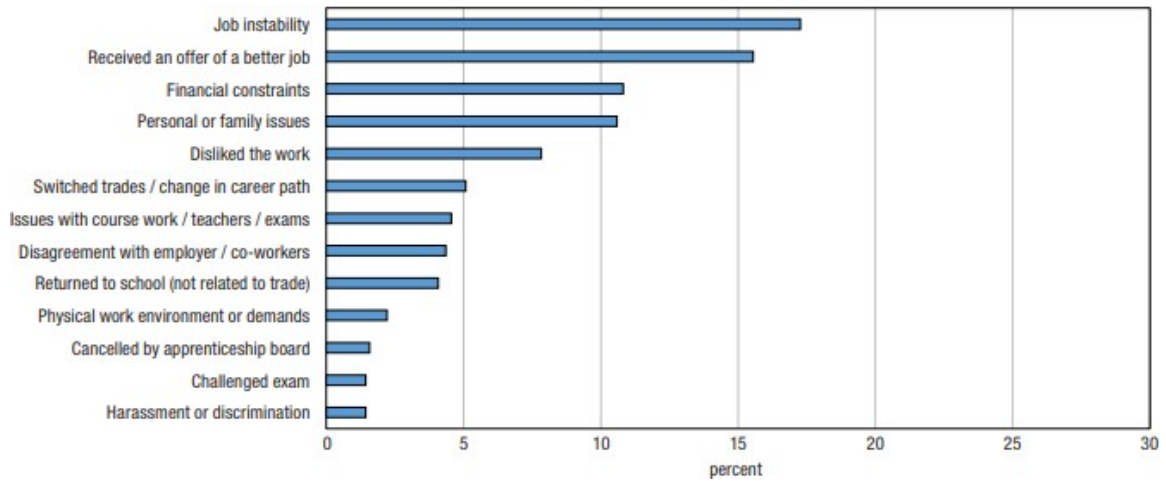

Frank, K. & Jovic, E. (2015). Apprenticeship status 2011-2013 [Image]. In National apprenticeship survey 2015. (p. 14). Ottawa, ON: Statistics Canada

Frank, K. & Jovic, E. (2015). Main reason reported by discontinuers [Image]. In National apprenticeship survey 2015. (p. 24). Ottawa, ON: Statistics Canada

HANDOUT: Flowchart: Backhoe Operation (2 pages)
Skill Builder: Flowcharts

IN THE WORKPLACE: A common use for flowcharts is to display processes at a glance and identify steps in those processes where decisions may be required.





Use the information on backhoe operation to create a flowchart about starting a backhoe. Use the symbols on the next page to help you.

- Make sure the chart is logical and that you can explain why you ordered the steps as you did.
- You must include at least 3 decision points showing YES and NO options
- The flowchart must have a start and a finish
- Use the appropriate shapes for each step in the flowchart
- Label the flowchart

Backhoe Operation: Backhoes are designed to do one thing: dig. But that does not mean that anyone can just jump in and safely start digging. There are a number of steps that need to be completed to ensure safe operation. Many of the steps are related to the condition of the machine itself. Others have to do with ensuring that the controls are set to the appropriate task.

1. Walk around backhoe and check for damaged or worn parts. Replace as needed.
2. Check all fluids (fuel, oil, hydraulic fluid, DEF, and coolant/anti-freeze). Top up as needed.
3. Ensure the boom is locked and swing lock is in place before driving the machine
4. Get in.
5. Confirm correct digging control pattern is selected: backhoe or excavator digging. Adjust controls to suit task if required.
6. Crank engine and allow to warm up.
7. Engage controls.
8. Honk the horn prior to moving the machine to alert those nearby and then move to dig site.
9. Engage the stabilizers to prevent the machine from rocking or tipping. If unable to stabilize adjust location.
10. Reengage stabilizers.
11. Dig

Common flowchart symbols:

Symbol	Name	What it means
	Start/Stop	A circle, oval or rounded rectangle starts or ends the process.
	Step/Task	A rectangle means a step in the process or a task. Slanted rectangles usually mean sub-steps or sub-processes.
	Process Direction	Arrows and lines indicate the order of the steps.
	Decision Point	A diamond shape means that you need to make a choice or decision.

HANDOUTS: Hazard Assessment (2 pages)
Skill Builders: Key Words & Phrases, Entry Forms

IN THE WORKPLACE: Assessing and reporting on hazards is a common task across trades. The ability to do so accurately is important as the reports impact the future safety of workers. Workers complete assessments prior to the start of each new task or when conditions have changed. Always check your work area for hazards prior to starting work as and check the condition of all tools and equipment.

Read the **Hazard Assessment Form** to complete the tasks and locate answers to the questions. Write the answers in the space provided and complete the form as requested.

1. What date format is required?

2. Who should the completed form be given to?

3. For each identified hazard, identify an appropriate control from the options.

a) Confined space: _____

b) Animal droppings: _____

c) Unsafe equipment: _____

d) Sharp objects: _____

4. Complete the assessment form to identify any hazards in the room you are currently working in (or an outside space or class shop if available). Work with a partner or in a small group. Compare your results with another team who assessed the same space.

HAZARD ASSESSMENT FORM				
This purpose of this assessment is to identify hazards associated with your work tasks, and to ensure hazards are controlled prior to starting work. Provide completed copies of this form to your supervisor. For assistance contact the Occupational Health and Safety Coordinator.				
WORK LOCATION:		Work Crew:		
DESCRIPTION OF JOB OR TASK:				
SUPERVISOR IN CHARGE:		ASSESSMENT DATE (D/M/Y):		
POTENTIAL HAZARDS (Check all that apply and add others as required)				
<input type="checkbox"/> Confined Space	<input type="checkbox"/> Extreme heat / cold	<input type="checkbox"/> Mould	<input type="checkbox"/> Obstructions	<input type="checkbox"/> Fall hazards
<input type="checkbox"/> Working Alone	<input type="checkbox"/> Noise	<input type="checkbox"/> Electrical	<input type="checkbox"/> Slip/Trip Hazards	<input type="checkbox"/> Unsafe tools
<input type="checkbox"/> Awkward postures or lifting	<input type="checkbox"/> Asbestos	<input type="checkbox"/> Lighting	<input type="checkbox"/> Mechanical	<input type="checkbox"/> Unsafe equipment
<input type="checkbox"/> Hazardous gases/chemicals	<input type="checkbox"/> Sharp objects	<input type="checkbox"/> Animal droppings	<input type="checkbox"/> Entrapment	<input type="checkbox"/>
OTHER HAZARDS OR INFORMATION:				
REQUIRED HAZARD CONTROLS (Check all that apply and add additional controls in the available space).				
Lockout tag out procedure	<input type="checkbox"/>	Mechanical ventilation	<input type="checkbox"/>	
Hard hat	<input type="checkbox"/>	Ladders for safe access and egress	<input type="checkbox"/>	
Protective gloves	<input type="checkbox"/>	Mechanical aids (dolly etc.)	<input type="checkbox"/>	
Respirator	<input type="checkbox"/>	Atmospheric testing	<input type="checkbox"/>	
Eye protection	<input type="checkbox"/>	Emergency or rescue procedure	<input type="checkbox"/>	
Protective footwear	<input type="checkbox"/>	Scaffolds (Inspected and tagged)	<input type="checkbox"/>	
Hearing protection	<input type="checkbox"/>	Work Permit	<input type="checkbox"/>	
Coveralls	<input type="checkbox"/>	Additional training	<input type="checkbox"/>	
Pedestrian Barricades	<input type="checkbox"/>	Machine guarding	<input type="checkbox"/>	
Stand by worker	<input type="checkbox"/>	Check in protocol with office	<input type="checkbox"/>	
Confined Space Entry Procedures	<input type="checkbox"/>	Fire extinguisher	<input type="checkbox"/>	
Additional Lighting (e.g. Flashlight)	<input type="checkbox"/>	Fall protection	<input type="checkbox"/>	
Communication device	<input type="checkbox"/>	Other	<input type="checkbox"/>	
Additional Controls or Comments (Use back of page if necessary):				

HANDOUT: Incident Report (4 pages)
Skill Builders: Key Words & Phrases, Entry Forms

IN THE WORKPLACE: Workers use incident reports to document the exact details of an unusual event that occurred at work, such as an injury to a worker or customer. Accuracy is important as the report may form part of a legal proceeding.

The article, **Site supervisor fined following workplace incident at gravel crushing pit**, describes a real workplace incident in Saskatchewan.

Use the information in the article to complete the **Incident Report** as if you had observed the accident. Complete as much of the report as you can.

Use point form to complete the following sections:

- Basic description of the occurrence
- Causes that led to the incident
- Actions taken to prevent recurrence (NOTE: this information is not explicitly provided in the article so use your best judgement and experience)

INCIDENT REPORT

GENERAL INFORMATION		
Name of Person Completing Report:		
Name of Injured or Affected Person:		<input type="checkbox"/> Employee <input type="checkbox"/> Customer
Incident Date:	Time of Occurrence:	Facility:
Department:		Location (specific):

INCIDENT TYPE		
<input type="checkbox"/> Slip/Trip/Fall	<input type="checkbox"/> Cut	<input type="checkbox"/> Property Damage
<input type="checkbox"/> Personal Illness	<input type="checkbox"/> Struck by	<input type="checkbox"/> Property Theft
<input type="checkbox"/> Ergonomic	<input type="checkbox"/> Caught in	<input type="checkbox"/> Fire / Flood Hazardous Spill / Leak
<input type="checkbox"/> Inappropriate Conduct	<input type="checkbox"/> Chemical Exposure	<input type="checkbox"/> Other:
<input type="checkbox"/> Violence / Threat / Harassment	<input type="checkbox"/> Biohazard Exposure	

OTHER PERSONNEL INVOLVED AND WITNESSES		
Name	Department	Phone / Contact
1		
2		
3		

BASIC DESCRIPTION OF OCCURRENCE
<input type="checkbox"/> See Attached Documentation

FIRST AID / MEDICAL RESPONSE	
First Aid Provided: <input type="checkbox"/> Yes <input type="checkbox"/> No	Ambulance Involved: <input type="checkbox"/> Yes <input type="checkbox"/> No
First Aider:	Sent to Hospital: <input type="checkbox"/> Yes <input type="checkbox"/> No
<input type="checkbox"/> Emergency First Aider <input type="checkbox"/> Standard First Aider	Medical Facility:
<input type="checkbox"/> Security <input type="checkbox"/> Other:	Time Off Site:
Details of the first aid that was provided:	

SEE OVER

Rev. 201708

Incident Report

CAUSES THAT LED TO THE INCIDENT

CAUSES THAT LED TO THE INCIDENT

ACTIONS TAKEN TO PREVENT RECURRENCE

ACTIONS TAKEN TO PREVENT RECURRENCE

REPORTED TO

Authority	Name	Date	Case / Ref #:
Supervisor / Director / Dean			N/A
Human Resources			N/A
Workers' Compensation Board			
Police			

REPORT COMPLETED BY

Name	Position	Date	Time

SIGNATURE:

SENIOR MANAGEMENT REVIEW

Name	Position	Date

SIGNATURE:

**Send completed original form to Occupational Health & Safety
by interoffice mail or email to safety@organization.ca**

Site supervisor fined following workplace incident at gravel crushing pit.

Failure to follow safety protocols at a gravel crushing pit near Wakaw led to serious injuries for one man last year, and now, fines against the supervisor on shift at the time.

Bradley Davidson was fined a total of \$4,900 in Prince Albert Provincial Court Friday in connection with the workplace incident, which happened June 2, 2017. Davidson, 28, pleaded guilty to one violation under the province's Occupational Health and Safety Act.

Davidson was employed for nine years with the same company at the time of the incident, and was supervising operations at the site, located about seven kilometres outside Wakaw. The company was not charged in connection with the incident.

At the time of the accident, a worker on the gravel crushing crew was working at the site feeding gravel into the conveyor with a loader, when the machine was switched off and he was ordered to clear debris. While still up in the air on the conveyor, Davidson started up the machine, failing to do a visual check and ensure the man had safely cleared the area.

Unable to get anyone's attention once the machine started up and knowing that he was going to be pushed through the conveyor, the man decided to go feet first, but caught his arm on a roller, breaking it, before continuing to travel through the machine. The momentum of the conveyor continued to push him through three more levels of the conveyor before he fell some 12 feet to the ground.

Along with a broken arm, the man suffered a split pelvis, deflated lung, a C-1 spinal fracture and broken ribs. He spent 17 days in hospital following the incident and seven months off work.

Miraculously, he was able to return to work, and his lawyer said he continues to be good friends with Davidson despite the workplace incident. The lawyer also said workplace incidents are taken seriously, and asked for a fine totaling \$10,500 in court last week, and that "This is a situation where Mr. Davidson simply didn't follow the procedures that he was supposed to follow, that he was trained to follow," she added.

Court heard Friday that Davidson no longer works for the company.

Tebbutt, C. (Sept. 20, 2018). Site supervisor fined following workplace incident at gravel crushing pit. paNOW. <https://panow.com/2018/09/10/site-supervisor-fined-following-workplace-incident-at-gravel-crushing-pit/>

HANDOUTS: Invoice 3 (3 pages)
Skill Builders: Entry Forms, Tables

IN THE WORKPLACE: Accurately entering and verifying information in complex forms such as invoices and work orders is a common task across trades. Errors in costs, hours worked, and materials to be delivered can result in significant losses to the company in time and hours worked.

Read the **RyCan Contractors Invoice** to complete the tasks and locate answers to the questions. Write the answers in the space provided or **highlight** the information on the invoice.

1. What is the invoice number?

2. When was the invoice issued?

3. What is the last date payment should be made?

4. What 3 ways can payment be made?

5. If paying by cheque, what name should the cheque be issued to?

6. What is the full name of the person who placed the order?

7. What is the product number?

8. What is the % of tax being charged?

9. If the apprentice's time is billed out at \$25 an hour, how much of the total labour charge is for the journey person's time?

10. The company offers a discount to educational institutions on invoices over \$8,000 before tax. Is the university eligible for the discount? How do you know?

RyCan Contractors

123 Market Street
 Kamloops, BC V1S 1A4
 Phone: 898-123-1234

INVOICE

INVOICE # 9-23
 DATE: OCT/23/2018

TO:
 Chris Adam
 Thompson College
 805 TC Drive
 Kamloops, BC, V2C 028
 Phone: 250-555-5555

SHIP TO:
 Same as ordered.

COMMENTS OR SPECIAL INSTRUCTIONS:

Removal of existing toilets and replacement with low-flo high-efficiency models.

SALESPERSON	P.O. NUMBER	REQUISITIONER	SHIPPED VIA	TERMS
J.B. Bowen	Same as invoice #	C. Adam	NA	30 days from invoice date

QUANTITY	DESCRIPTION	UNIT PRICE	TOTAL
7	Afwell millennial commercial toilets #3127X3 (white)	763.00	5,341.00
7	Replacement batteries	27.00	189.00
7	Recycling/disposal fees	60.00	420.00
8	Labour: Journeyperson + apprentice (8 hours)	165.00	1,320.00
SUBTOTAL			7270.00
SALES TAX			945.10
SHIPPING & HANDLING			NA
TOTAL DUE			8,215.10

Payment may be made by credit card, billed to account, or by cheque.
 Make all cheques payable to RCP Contractors.
 If you have any questions concerning this invoice, please contact us.

THANK YOU for your business!

HANDOUTS: Line Drawings (2 pages)
Skill Builders: Technical Drawings

IN THE WORKPLACE: Contractors, estimators, builders and tradespersons all rely on technical drawings for the information they need to safely and accurately build and repair large and small construction.

- Match the numbered images on the left with the correct definition on the right.

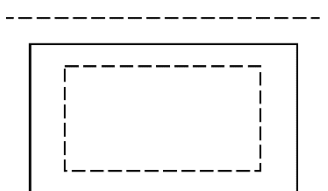
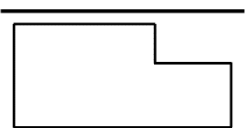
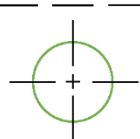
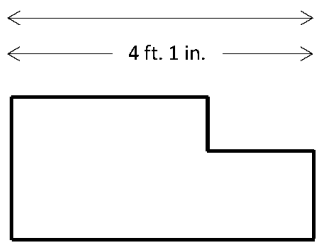
Line #	Example	Def.
1		
2		
3		
4		

Def.	Definition
A	Centre Line: Long and short dash lines. Usually indicates centre of holes, circles and arcs. Line is thin and dark.
B	Dimension Line: Thin and dark lines use to show the size (span) of an object with a numeric value. Usually terminates with arrowheads or tick markings. Often shown with a break in the middle where the measurement will be noted.
C	Hidden line: Short dashed lines use to show nonvisible surfaces. Usually shows as medium thickness.
D	Property Line: Long dashes alternating with two short dashes. This line is used to show the actual legal line of the property.
E	Leader Line: Medium line with arrowhead to show notes or to label for size or special information about a feature.
F	Extension Line: Thin and dark line used to show the start and end of a dimension. The extension line does not touch the object and it ends just past the head of the arrow.
G	Object or Visible line: Thick dark line use to show outline of an object, visible edges and surfaces.

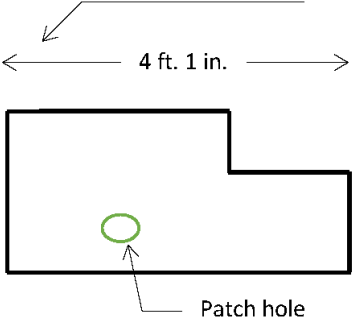
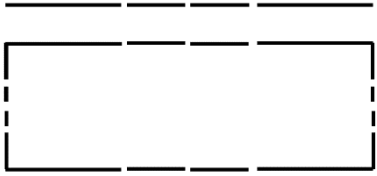
<p>5</p>		
<p>6</p>		
<p>7</p>		

2. Locate a complex line drawing in your technical training materials and identify as many of the line types as you can. If there are differences in how the lines are used, what do you think the reason for that is?

HANDOUT: Log Book: HEO (3 pages)
Skill Builder: Entry Forms

IN THE WORKPLACE: Accurately entering and verifying information in complex forms such as log books, invoices and work orders is a common task across trades. Tracking time has direct connection to a range of tasks including machinery use related to certification requirements and to monitoring project costs. Accuracy is important when using log books as they are considered to be legal documents.

Refer to the **Log Book Index** to complete the tasks and locate answers to the questions. Write the answers in the spaces provided or **highlight** the information in the log book.

- Under the subheading "From" in what order should the date information be entered?

- In what month was the excavator entry completed?

Use the following information to answer the next questions:

- "Period of Operation" refers to the total number of days, full weeks and full months the activity occurred in.
- The period of operation for the backhoe was incorrectly recorded and actually ended on June 11, 2015. Correct the entry using the boxes provided below.

	Type of Machine	Date			Date			Period of Operation		
Page	Model and Size	From			To			days/weeks/months		

- Enter the correct number of months to complete entry 5.

- Complete the "To" line for entry 6.

6. On which machine did the operator complete the greatest number of days?

7. On which machine did the operator complete the fewest number of days?

8. Add a 7th entry using the following information:

- a. Same equipment as first entry
- b. Started work 14 days after entry 6 was completed
- c. Worked 6 months and 3 days

Operators Log Book Index

	Type of Machine	Date			Date			Period of Operation		
Page	Model and Size	From			To			days/weeks/months		
1	<i>Excavator, Hitachi</i>	26	04	14	14	09	14	5	2	4
2	<i>Backhoe, Caterpillar</i>	15	09	14	06	11	15	1	3	13
3	<i>Loader, John Deere</i>	15	11	15	30	03	16	1	2	4
4	<i>Grader, Caterpillar</i>	10	04	16	18	11	16	1	1	7
5	<i>Dozer, Hitachi</i>	20	11	16	23	04	17	3	0	
6	<i>Wheel skidder, Hitachi</i>	07	05	17	01	08		4	3	14
7										
8										
9										
10										
11										
12										

Bow Valley College. (2020). Operators Log Book Index. [Table]. Calgary, Canada: Author

HANDOUT: Maintenance Schedule: Sprinkler (3 pages)
Skill Builder: Entry Forms, Tables & Lists

IN THE WORKPLACE: Scheduling maintenance means that machinery is less likely to break down. Following and accurately verifying information in workplace forms such as maintenance schedules is a common task across trades. For example, to make sure that sprinkler systems are reliable, plumbers must perform periodic inspection and maintenance of all system components.

Read the **Sprinkler Maintenance Schedule** to complete the tasks and locate answers to the questions. Write the answers in the space provided or **highlight** the information in the form.

1. Which tasks need to be performed 4 times a year?

2. How often should dry trip tests be performed?

3. How often should wet trip tests be performed?

4. What sprinkler tests relate to water flow?

5. How often should alarms be inspected?

6. What types of valves need to be inspected?

7. Assuming the year starts January 1, complete the calendar to show when the following tasks need to be performed during February. Enter the corresponding letter (A, B, etc.) on the day you would schedule the maintenance

- A. Check water level in tanks
- B. Start fire pumps
- C. Check air pressure
- D. Inspect and test controllers
- E. Inspect valves for open position.

February

Sun	Mon	Tue	Wed	Thu	Fri	Sat
					1	2
3	4	5	6	7	8	9
10	11	12	13	14	15	16
17	18	19	20	21	22	23
24	25	26	27	28		

8. Assuming the year starts January 1, what additional tasks would have to be completed in March?

Summary of Inspection and Test Frequencies for Sprinkler Systems.

	Weekly	Monthly	Quarterly	Annually	Every 3 years
Check general condition of sprinklers and sprinkler system				X	
Conduct flow tests of open sprinklers				X	
Conduct main drain tests			X		
Test water flow alarms		X			
Check air and water pressure in dry pipe systems	X				
Trip test dry pipe valves				X	
Drain low points in dry pipe systems				X	
Trip test deluge and pre-action systems				X	X ¹
Trip test high-speed suppression systems					X
Check general condition of standpipe systems			X		
Perform water flow tests				X	
Check general condition of hydrants				X	
Check general condition of fire department connections				X	
Check water levels in tanks	X				
Check general condition of water storage tanks				X	
Check water level and air pressure in pressure tanks	X				
Check general condition of pressure tanks				X	
Check tank heating systems				X	
Inspect and test cathodic protection equipment				X	
Start fire pumps	X				
Check fuel supply to engine drivers	X				
Perform fire pump flow tests				X	
Inspect and test controllers				X	
Inspect valves for open position		X			
Conduct general preventive maintenance inspection of valves				X	
Inspect check valves, water flow meters, and backflow preventers					X ¹
Test pressure regulating and altitude valves				X	
1- Annual trip test may be dry: wet trip test including flow of water through heads/nozzles shall be conducted a minimum of once every 3 years.					

Bow Valley College. (2020). Sprinkler Maintenance Schedule. [Entry Form]. Calgary, Canada: Author

HANDOUTS: Mileage Log (2 pages)
Skill Builder: Entry Forms, Tables & Lists

IN THE WORKPLACE: Accurately calculating information in complex forms such as mileage logs and invoices is a common task across trades. Basic math errors can result in you being under or overpaid, or a client's bill not being accurate.

Use the **Mileage Form** to complete the following tasks.

1. Use the following information to complete as much of the form as you can:
 - a. Rate per km - .56
 - b. Employee ID # - 0015822
 - c. Driving period was 1 week (7 days)
 - d. Log was authorized 2 days after the last entry was made
 - e. Distance from office to warehouse = 12 km
 - f. Distance from warehouse to Site A = 22 km
 - g. Distance from office to Site B = 17 km

2. Calculate the total mileage and total reimbursement. Need help? Use your phone or a calculator.

Mileage Log

Employee name	Alex Wu		Rate per km		Do not write here:	
ID			For period	13/09/19 ---		
Authorized by	LG		Total mileage			
Authorized on			Total reimbursement	\$		
Date	Starting Location	Destination	Odometer start	Odometer end	Mileage	Reimbursement
13/09/19	Office	Site B	23111			
15/09/19	Warehouse	Site A (return trip)		23200		
17/09/19	Office	Warehouse	23209			
18/09/19	Site A		23241	23263		
19/09/19	Site B	Office	23277			

Bow Valley College. (2020). Mileage Log. [Entry Form]. Calgary, Canada: Author

Handouts: Project Schedule (2 pages)
Skill Builder: Key Words & Phrases, Charts & Graphs

IN THE WORKPLACE: Staying on schedule is critical to staying on budget and having the required resources (human and material) available when needed. A shared project schedule helps plan for potential problems and ensures neither time nor money are wasted.

Refer to the **Schedule: Solar Panel Installation** to locate the answers to the following questions.

1. What is the project completion date?

2. Who is responsible for the wiring and how many days will they need?

3. Who is responsible for the greatest number of project days? How many?

4. What tasks must be completed before the materials are purchased?

5. If the inspection is moved up a week, what task(s) definitely need to be rescheduled? What additional task(s) may need to be rescheduled?

6. How many work days can the procurement of the PV modules be delayed without impacting the schedule?

Schedule: Solar Panel Installation

Task	Who	June 3					June 10					June 17					June 24				
		M	T	W	T	F	M	T	W	T	F	M	T	W	T	F	M	T	W	T	F
Design and engineer	JK	█																			
Obtain permits	RT		█																		
Procure materials	RT					█															
Install roof attachments	WM						█														
Assemble racking	WM									█											
Install PV modules	WM											█									
Install DC wiring	SR							█													
Install AC system	WM														█						
Inspection	JK																			█	
Run Test	JK/WM																			█	

Note: Project dates refer to the first workday of that week.

Bow Valley College. (2020). Schedule: Solar Panel Installation. [Gantt chart]. Calgary, Canada: Author

HANDOUTS: Product Recall: Chainsaw (4 pages)
Skill Builders: Key Words & Phrases, Scanning, Tables & Lists

IN THE WORKPLACE: Health Canada issues product alerts and recalls that are designed to keep consumers and workers safe. “Safety alerts” are issued as suggestions, but if a product is recalled it is always considered a danger to human health or safety. This means it could cause injury, death or adverse health effects as a result of its normal use. The Health Canada website has a special section dedicated to the recall of Tools and Electrical Products.

Read the **Product Recall Alert** to locate the following information. **Highlight** the information in the document or write your answers in the space provided.

1. When was the recall issued?

2. How many Makita DCS products are included in the recall?

3. How many of the affected units were sold in Canada?

4. Is a Dolmar PS7900 purchased in January 2002 affected?

5. What is another word for laceration?

6. What are the 3 classes of chainsaw included in the recall?

7. What is the hazard and the related danger in using the recalled chainsaws?

8. What should a person who owns a chainsaw in the list do?

9. Can the chainsaws be repaired? At what cost?

10. What company manufactures the chainsaws?

11. The information in a product recall alert is divided into 3 sections. What would you title each section?

12. Google the product alert page of the Government of Canada website. Go to the “Tools and Electrical Products” section and select a product under current or past recall. Scan the alert for the required information to complete the table below.

Date of alert	
Affected products	
Model number	
Identified hazard	
Name of manufacturer	
Instructions to consumer	

Makita Canada Inc. recalls Makita and Dolmar Chainsaws

Starting date: July 19, 2018
Posting date: July 19, 2018
Type of communication: Consumer Product Recall
Subcategory: Tools and Electrical Products
Source of recall: Health Canada
Issue: Laceration Hazard
Audience: General Public
Identification number: RA-67192

Affected products

Makita and Dolmar 64, 73 and 79 cc Gas Powered Chainsaws

Product description

This recall involves Makita and Dolmar brand chainsaws in the 64, 73 and 79 cc classes. These chainsaws were sold with and without chainsaw bars and chains. The motor housing/fuel tank are either red/orange or teal blue in colour.

The model number and date of manufacture are located on the label at the back of the saw near the handle. The table below provides the model number and date of manufacture of the affected chainsaws.



The following products are included in this recall.

Class	Brand	Model Number	Date of Manufacture	
64cc	Makita	DCS6401-PH DCS6421-20	Before June 1, 2018	
	Dolmar	PS6400		
73cc	Makita	DCS7301-PH EA7300P50E EA7300P50E	Before June 1, 2018	
		Dolmar		PS7300 PS7310
	Makita			DCS7901-PH
		Dolmar		PS7900 PS7910



Hazard identified

The automatic chain brake does not easily engage when the saw kicks back, possibly exposing the user to contact with the chain while it is still moving, posing a laceration hazard.

As of July 4, 2018, the company has received no report of incident or injury in Canada.

Number sold

Approximately 2,503 units of the affected products were sold in Canada.

Time period sold

The affected products were sold in Canada from April 2002 to June 2018.

Place of origin

Manufactured in Germany

Companies:

Distributor: Makita Canada Inc.
Whitby, Ontario
CANADA

Manufacturer: Dolmar GMBH, Makita Engineering
Hamburg
GERMANY

What you should do

Consumers should immediately stop using the affected chainsaws, and take the saw to the nearest Makita Canada Factory Service Centre to have the saw examined and repaired free of charge.

For more information, consumers may contact the nearest [Makita Factory Service Centre](#), by [email](#) or by visiting the company's [website](#).

Please note that the Canada Consumer Product Safety Act prohibits recalled products from being redistributed, sold or even given away in Canada.

Health Canada would like to remind Canadians to report any health or safety incidents related to the use of this product or any other consumer product or cosmetic by filling out the [Consumer Product Incident Report Form](#).

This recall is also posted on the [OECD Global Portal on Product Recalls website](#). You can visit this site for more information on other international consumer product recalls.

Date modified: 2018-08-03

Health Canada. (July 19, 2018). Makita Canada Inc. recalls Makita and Dolmar chainsaws.

<https://healthycanadians.gc.ca/recall-alert-rappel-avis/hc-sc/2018/67192r-eng.php>

Note: content has been edited for space. Do not assume all information is accurate.

HANDOUTS: Product Recall: Digital Clamp Meters (4 pages)
Skill Builders: Key Words & Phrases, Scanning, Tables & Lists

IN THE WORKPLACE: Health Canada issues product alerts and recalls that are designed to keep consumers and workers safe. “Safety alerts” are issued as suggestions, but if a product is recalled it is always considered a danger to human health or safety. This means it could cause injury, death or adverse health effects as a result of its normal use. The Health Canada website has a special section dedicated to the recall of Tools and Electrical Products.

Read the **Product Recall Alert** to locate the following information. **Highlight** the information in the document or write your answers in the space provided.

1. When was the recall issued?

2. How many meter types are included in the recall?

3. How many of the affected units were sold in Canada?

4. Is an EX655 purchased in April 2016 affected?

5. What years were the recalled meters distributed?

6. Which Exech meters are not included in the recall?

7. What is the hazard and the related danger in using the recalled meters?

8. What should a consumer do right away?

9. Can a consumer have the meters repaired?

10. What company manufactures the meters?

11. The information in a product recall alert is divided into 3 sections. What would you title each section?

12. Google the product alert page of the Government of Canada website. Go to the “Tools and Electrical Products” section and select a product under current or past recall. Scan the alert for the required information to complete the table below.

Date of alert	
Affected products	
Model number	
Identified hazard	
Name of manufacturer	
Instructions to consumer	

Extech recalls Digital Clamp Meters

Starting date: May 25, 2017
Posting date: May 25, 2017
Type of communication: Consumer Product Recall
Subcategory: Tools and Electrical Products
Source of recall: Health Canada
Identification number: RA-67192

Affected products

Extech AC/DC Digital Clamp Meters

Product description

This recall involves AC/DC digital clamp meters that are used to measure AC/DC voltage, resistance, capacitance, frequency, temperature, continuity, and diode.

The following products are included in this recall.

Model number	Serial number	Date Code	UPC Code	Certification File Number
EX650	R15XXXXXXXX	2015	793950396506	UL E201687
EX655	R15XXXXXXXX	2015	793950396551	UL E201687
MA160	R17XXXXXXXX	2016	793950316016	ETL 150112090GZU-001
MA61	R15XXXXXXXX	2015-2016	793959370612	ETL 150609099GZU-001
MA63	R15XXXXXXXX	2015-2016	793950370636	ETL 150609099GZU-001

The model number can be found on the front of the unit and the serial number is on the back. Serial numbers ending with an "A" are not included in the recall.



Hazard identified

The clamp meters terminal input screws can come loose which can fail to give accurate readings, causing the user to falsely believe that the electrical power of the test subject is low or off, posing an electrocution hazard.

As of May 17, 2017 the company has received no report of incidents in Canada and no reports of injury. In the United States, the company has received reports of the screw coming loose and no reports of injury.

Number sold

Approximately 21 units of the affected products were sold in Canada and 800 were sold in the United States.

Time period sold

The affected products were sold in Canada from January 2016 to April 2017.

Place of origin

Manufactured in China

Companies:

Distributor: Extech
Goleta, California
UNITED STATES

Manufacturer: Uni-Trend Technology Limited
Guandong
CANADA

What you should do

Consumers should immediately stop using the meter and contact Extech for an exchange.

For more information, or to register for an exchange, consumers can contact Extech by phone at 111-111-1111, Monday to Friday 9:00 am to 5:00 pm EST, by email, or by visiting the company website and clicking on “Safety Notices” at the bottom of the page.

Please note that the Canada Consumer Product Safety Act prohibits recalled products from being redistributed, sold or even given away in Canada.

Health Canada would like to remind Canadians to report any health or safety incidents related to the use of this product or any other consumer product or cosmetic by filling out the [Consumer Product Incident Report Form](#).

This recall is also posted on the [OECD Global Portal on Product Recalls website](#). You can visit this site for more information on other international consumer product recalls.

Date modified: 2017-05-25

Ref: Health Canada. (2017). Recalls and safety alerts: digital clamp meters.

<https://healthycanadians.gc.ca/recall-alert-rappel-avis/hc-sc/2017/63356r-eng.php>

Note: content has been edited for space. Do not assume all information is accurate.

HANDOUTS: Product Recall: Torch Handles (4 pages) Skill Builders: Key Words & Phrases, Scanning, Tables & Lists

IN THE WORKPLACE: Health Canada issues product alerts and recalls that are designed to keep consumers and workers safe. “Safety alerts” are issued as suggestions, but if a product is recalled it is always considered a danger to human health or safety. This means it could cause injury, death or adverse health effects as a result of its normal use. The Health Canada website has a special section dedicated to the recall of Tools and Electrical Products.

Read the **Product Recall Alert** to locate the following information. **Highlight** the information in the document or write your answers in the space provided.

1. When was the recall issued?

2. What brand names was the product sold under?

3. How many of the affected units were sold in Canada?

4. Is a WELD-HDL 18-5 purchased in December 2014 affected?

5. What does the model number prefix 440 indicate?

6. Which Harris handles are not included in the recall?

7. What is the hazard and the related danger in using the recalled product?

8. What should a consumer do both right away and later?

9. What 2 ways is the product sold?

10. Where and by what company is the product?

11. The information in a product recall alert is divided into 3 sections. What would you title each section?

12. Google the product alert page of the Government of Canada website. Go to the “Tools and Electrical Products” section and select a product under current or past recall. Scan the alert for the required information to complete the table below.

Date of alert	
Affected products	
Model number	
Identified hazard	
Name of manufacturer	
Instructions to consumer	

Harris Products Group recalls torch handles

Starting date: July 31, 2014
Posting date: July 31, 2014
Type of communication: Consumer Product Recall
Subcategory: Tools and Electrical Products
Source of recall: Health Canada
Issue: **Fire Hazard**
Identification number: RA-40729

Affected products

Torch handles used for welding, cutting, brazing, soldering and/or heating

Product description

This recall involves two models of torch handles that were manufactured from December 1, 2013 through March 31, 2014 and sold under the Lincoln Electric Company and Harris Product Group names. The specific model of torch handles are:

- Model 18-5
- Model 85

All of the potentially affected torch handles are stamped with the model number and one of the following manufacturing codes: FM, GA, GB, and GC. Both the model number and the date code are stamped permanently into the torch handle at the end opposite to the valve.

These models are sold both individually and as part of an outfit (including hoses, tanks, regulators and other parts).

The list of products that contain the potentially-affected torch handles is as follows:

Description	Kit Model Number
WELD-HDL,85 WITH C/V	1401340
WELD-HDL,85 LECO	1401346
KIT,8525 C DLX RAD	4400250
KIT, STANDARD DUTY WE250A	4403209
KIT, 85601-510 DLX CUTWELDER BAG	4403212
KIT, 8525GX-510 DLX STEELWORKER BAG	4403224
VALVE-ASY VA85	9101228
VALVE-ASY VA63	9101230

Units with “0” above the word “Harris” and to the right of the rivet head are not included in this recall.

Hazard identified

The torch handles can leak oxygen or fuel, posing a fire hazard.

Neither Harris Products Group nor Health Canada has received reports of consumer incidents or injuries related to the use of the torch handles in Canada.

Number sold

Approximately 350 of the recalled torches were sold in Canada and approximately 13,000 in the United States through various retailers and gas distributors.

Time period sold

The recalled torch handles were sold from December 2013 to May 2014 in Canada and the United States.

Place of origin

Manufactured in Poland.

Companies:

Manufacturer: Harris Calorific International
Dzierzoniow
POLAND

Distributor: Harris Products Group
Gainesville, Georgia
UNITED STATES

What you should do

Consumers should immediately stop using the meter and contact Harris Products Group to receive a free replacement.

For more information, consumers may contact Harris Products Group by phone at 111-111-1111, Monday to Friday 9:00 am to 5:00 pm EST, or online and click on Recall for more information.

Please note that the Canada Consumer Product Safety Act prohibits recalled products from being redistributed, sold or even given away in Canada.

Health Canada would like to remind Canadians to report any health or safety incidents related to the use of this product or any other consumer product or cosmetic by filling out the [Consumer Product Incident Report Form](#).

Date modified: 2014-07-31

Ref: Health Canada. (July 31, 2014). Harris Products Group recalls torch handles.
<https://healthycanadians.gc.ca/recall-alert-rappel-avis/hc-sc/2014/40729r-eng.php>

Note: content has been edited for space. Do not assume all information is accurate.

HANDOUTS: Product Recall: Hot Water Boiler (4 pages) Skill Builders: Key Words & Phrases, Scanning, Tables & Lists

IN THE WORKPLACE: Health Canada issues product alerts and recalls that are designed to keep consumers and workers safe. “Safety alerts” are issued as suggestions, but if a product is recalled it is always considered a danger to human health or safety. This means it could cause injury, death or adverse health effects as a result of its normal use. The Health Canada website has a special section dedicated to the recall of Tools and Electrical Products.

Read the **Product Recall Alert** to locate the following information. **Highlight** the information in the document or write your answers in the space provided.

1. How long after the posting date was the recall information modified?

2. What 2 conditions can cause the seal to deteriorate?

3. How many of the affected units were sold in Canada?

4. Is a model Tft155 purchased in October 2018 affected? Why or why not?

5. What is the common UPC prefix for all of the recalled boilers?

6. What information is different between the Canadian and American reports?

7. What is the hazard and the related danger in using the recalled product?

8. What should a consumer do both right away and later?

9. Who can install the upgrade kit?

10. Where and by what company is the product distributed?

11. The information in a product recall alert is divided into 3 sections. What would you title each section?

12. Google the product alert page of the Government of Canada website. Go to the “Tools and Electrical Products” section and select a product under current or past recall. Scan the alert for the required information to complete the table below.

Date of alert	
Affected products	
Model number	
Identified hazard	
Name of manufacturer	
Instructions to consumer	

NY Thermal Inc. (NTI) recalls Trinity Tft Gas-Fired Hot Water Boilers

Starting date: May 15, 2018
Posting date: May 15, 2018
Type of communication: Consumer Product Recall
Subcategory: Household Items, Appliances
Source of recall: Health Canada
Issue: **Public Safety**
Identification number: RA-66672

Affected products

NTI Trinity Tft Gas-Fired Hot Water Boilers

Product description

This recall involves 10 models (see table below) of Trinity Tft Gas-Fired Hot Water Boilers.

The Serial Numbers range from 1000 to 1115541.

Model	UPC
Tft60	628233731005
Tft85	628233731036
Tft110	628233731067
Tft155	628233731098
Tft155	628233731128
Tft200	628233731159
Tft250	628233731180
Tft300	628233731210
Tft340	628233733467
Tft399	628233731241

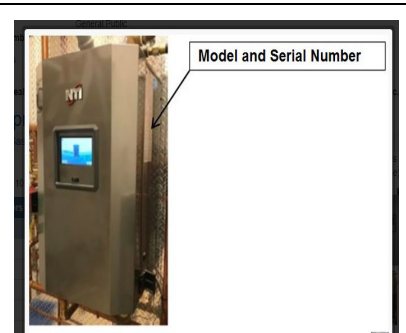

Hazard identified

Deterioration of the grommet seal in certain excessively used and/or improperly installed NTI boilers could potentially permit the escape of low levels of carbon monoxide.

As of April 30, 2018 the company has received 2 reports of grommet seal deterioration in Canada, and in one of those cases there was a report of a low level emission of carbon dioxide but no reports of injuries.

Number sold

Approximately 7359 of the affected products were sold in Canada and approximately 16,000 were sold in the United States.

Time period sold

The affected products were sold in Canada and the United States from October 7, 2011 to January 24, 2018.

Place of origin

Manufactured in United States.

Companies:

Manufacturer: Duravent
Albany, New York
UNITED STATES

Distributor: NY Thermal Inc.
Saint John, New Brunswick
CANADA

What you should do

Consumers should immediately stop using the recalled boilers and contact their installer to have an upgrade kit installed. The company will pay a certified installer to complete the upgrade. The upgrade is estimated to take approximately 10 minutes, and does not require the disconnection of the exhaust venting, gas or water lines.

For more information, consumers may contact NYI toll-free at 111-111-1111, Monday to Friday 7:00 am to 7:00 pm EST, or online through the company’s website.

Please note that the Canada Consumer Product Safety Act prohibits recalled products from being redistributed, sold or even given away in Canada.

Health Canada would like to remind Canadians to report any health or safety incidents related to the use of this product or any other consumer product or cosmetic by filling out the [Consumer Product Incident Report Form](#).

Date modified: 2018-05-25

Health Canada. (May 15, 2018). NY Thermal Inc. (NTI) recalls Trinity Tft gas-fired hot water boilers. <https://healthycanadians.gc.ca/recall-alert-rappel-avis/hc-sc/2018/66672r-eng.php>

Note: content has been edited for space. Do not assume all information is accurate.

HANDOUTS: SDS: Auto Service Technician (5 pages)

Skill Builder: Key Words & Phrases, Tables & Lists

IN THE WORKPLACE: According to the WCB (Workers' Compensation Board), it is each worker's responsibility to learn about hazardous products they use and to follow safe work procedures. Detailed information about hazardous products is provided in Safety Data Sheets, usually called SDS.

PART 1: SDS standards are set by law. Every SDS must contain information on the following 16 sections.

1. **Product and Company Information:** Includes product name, what the product is used for, the chemical name, the name of the manufacturer or suppliers with contact information.
2. **Hazardous Identification:** The related hazard classifications (with pictograms) and the potential health effects of each hazard associated with the product.
3. **Composition/Ingredients:** Chemical and common names of hazardous ingredients.
4. **First aid measures:** Immediate treatment and information for medical professionals.
5. **Fire-fighting measures:** Suitable extinguishers and instructions to fire-fighters.
6. **Accidental release measures:** What to do if the product spills out of its container.
7. **Handling and Storage:** Precautions for safe handling.
8. **Exposure Controls/Personal Protection:** Guidelines for safe use and required personal protective equipment (PPE).
9. **Physical and Chemical Properties:** Information such as product colour and smell and details related to the product's chemicals' effects on health, safety and the environment.
10. **Stability and Reactivity:** What happens to the product if it comes into contact with another product.
11. **Toxicological information:** How health can be affected by short-term and long-term exposure to the product.
12. **Ecological information:** Information on the environmental impact of the product.
13. **Disposal Considerations:** Information on safe waste disposal including packaging.
14. **Transport Information:** Shipping information such as the shipping classification and the Transport Canada PIN (Product Information Number) for the whole product.
15. **Regulatory Information:** Safety, health and environmental regulations specific to the product.
16. **Other information:** Details of any changes to the SDS since the last revision.

On the job you will need to look up information in the SDS. You want to be efficient and start with the section that will most likely have the answers you are looking for.

- Decide which of the 16 section of the SDS you would scan **first** to find the answer to each of the search questions below.
- Enter the **section number** of the section in the space provided.

Search Questions	Section (1-16)
1. What is the name of the product?	
2. What is the product made of?	
3. Where should the product be stored when not in use?	
4. What should you do if this product splashes in your eyes?	
5. Is the product made in Canada?	
6. If this product catches fire, how do you put it out?	
7. What sort of PPE should be worn when using this product?	
8. What should the product smell like?	
9. How can you dispose of leftover product?	
10. What are the US shipping codes for this product?	
11. What is the product used for?	
12. What hazards are associated with this product?	
13. What changes if any have been made since the last revision?	
14. Are there potential long term risks associated with using this product?	

PART 2: Locate the answers to the following questions in the SDS sections that follow. Highlight the answers or write the in the space provided below.

1. What is the name of the product?

2. What is the phone number to call in an emergency?

3. What month and year was the SDS last issued?

4. What should you do if the product gets in your eyes?

5. Where can you find information on what protective equipment to use?

6. When should a respirator be used as part of the PPE?

7. How stored the product be stored? Why?

8. Identify 2 recommended actions for how to clean up the product and 1 action that is not recommended.

9. What evidence is there that dust from the product may pose a health risk?

10. When should calling for medical help be the first response?



SAFETY DATA SHEET

SAFETY DATA SHEET NUMBER: ABS-BP-SDS-1

SECTION 1 - PRODUCT AND COMPANY IDENTIFICATION

PRODUCT NAME: Integrally Molded Brake Pad
MANUFACTURER / SUPPLIER: ABS Friction Inc.
 55 Taggart Street
 Guelph, ON
 Canada, N1L 1M9
 EMERGENCY PHONE NUMBER: (519) 763-9000
 8:30 AM to 4:30 PM ET
www.absfriction.com
PRODUCT USE: Vehicle brake pad
DATE OF PREPARATION: August 20, 2015

SECTION 4 - FIRST AID MEASURES

INHALATION: If symptoms are experienced (e.g. cough, irritation, etc.), remove victim to fresh air. If irritation persists, seek medical attention.
SKIN CONTACT: In case of irritation, remove contaminated clothing and flush affected areas with water. If irritation persists, seek medical attention.
EYE CONTACT: Remove any contact lenses. Immediately and continuously flush eyes with plenty of water for at least 15 minutes. If irritation persists, seek medical attention.
INGESTION: Seek medical attention.
PERSONAL PROTECTIVE EQUIPMENT FOR FIRST AID RESPONDERS: Not applicable

SECTION 6 – ACCIDENTAL RELEASE MEASURES

PERSONAL PRECAUTIONS: Wear appropriate personal protective equipment – refer to Section 8 for more information. This would include a particulate respirator if airborne dust is generated.
ENVIRONMENTAL PRECAUTIONS: Not applicable
METHODS AND MATERIALS FOR CONTAINMENT AND CLEANING UP: Avoid generating dust from this product. Clean up using methods that do not generate dust such as HEPA vacuum or wet clean up. Avoid using compressed air for removal of dust.

SECTION 7 – HANDLING AND STORAGE

HANDLING PROCEDURES AND EQUIPMENT: Handle in accordance with good industrial hygiene and safety practices. Minimize dust generation. Use adequate ventilation if dust is generated. Avoid contact with skin and eyes.
STORAGE REQUIREMENTS: Store the product in a dry area as contact with moisture may promote rust.
SENSITIVITY TO MECHANICAL IMPACT: Not sensitive
SENSITIVITY TO STATIC DISCHARGE: Not sensitive

ABS Friction. (August 20, 2015). Internally molded brake pad. [Safety Data Sheet]. <http://www.absfriction.com/pdf/MSDS.pdf>

Note: This document has been modified. Sections 2, 3, 5 and 8-16 are not included here. This document is not an official version.

HANDOUTS: SDS: Carpenter (5 pages)

Skill Builders: Key Words & Phrases, Tables & Lists

IN THE WORKPLACE: According to the WCB (Workers' Compensation Board), it is each worker's responsibility to learn about hazardous products they use and to follow safe work procedures. Detailed information about hazardous products is provided in Safety Data Sheets, usually called SDS.

PART 1: SDS standards are set by law. Every SDS must contain information on the following 16 sections.

1. **Product and Company Information:** Includes product name, what the product is used for, the chemical name, the name of the manufacturer or suppliers with contact information.
2. **Hazardous Identification:** The related hazard classifications (with pictograms) and the potential health effects of each hazard associated with the product.
3. **Composition/Ingredients:** Chemical and common names of hazardous ingredients.
4. **First aid measures:** Immediate treatment and information for medical professionals.
5. **Fire-fighting measures:** Suitable extinguishers and instructions to fire-fighters.
6. **Accidental release measures:** What to do if the product spills out of its container.
7. **Handling and Storage:** Precautions for safe handling.
8. **Exposure Controls/Personal Protection:** Guidelines for safe use and required personal protective equipment (PPE).
9. **Physical and Chemical Properties:** Information such as product colour and smell and details related to the product's chemicals' effects on health, safety and the environment.
10. **Stability and Reactivity:** What happens to the product if it comes into contact with another product.
11. **Toxicological information:** How health can be affected by short-term and long-term exposure to the product.
12. **Ecological information:** Information on the environmental impact of the product.
13. **Disposal Considerations:** Information on safe waste disposal including packaging.
14. **Transport Information:** Shipping information such as the shipping classification and the Transport Canada PIN (Product Information Number) for the whole product.
15. **Regulatory Information:** Safety, health and environmental regulations specific to the product
16. **Other information:** Details of any changes to the SDS since the last revision.

On the job you will need to look up information in the SDS. You want to be efficient and start with the section that will most likely have the answers you are looking for.

- Decide which of the 16 sections of the SDS you would scan **first** to find the answer to each of the search questions below.
- Enter the **section number** of the section in the space provided.

Search Questions	Section (1-16)
1. What is the name of the product?	
2. What is the product made of?	
3. Where should the product be stored when not in use?	
4. What should you do if this product splashes in your eyes?	
5. Is the product made in Canada?	
6. If this product catches fire, how do you put it out?	
7. What sort of PPE should be worn when using this product?	
8. What should the product smell like?	
9. How can you dispose of leftover product?	
10. What are the US shipping codes for this product?	
11. What is the product used for?	
12. What hazards are associated with this product?	
13. What changes if any have been made since the last revision?	
14. Are there potential long term risks associated with using this product?	

PART 2: Locate the answers to the following questions in page 1 of the SDS. Highlight the answers or write them in the space provided below.

1. What is the name of the product?

2. What is the phone number to call in a medical emergency?

3. What month and year was the SDS last issued?

4. What should you do if the product gets in your eyes?

5. How can you prevent the product getting in your eyes?

6. What 3 types of personal protection equipment should be worn when using the product?

7. After the product container is closed, identify 3 precautions for how it should be stored.

8. One hazard of the product is that it is highly flammable. Identify 2 ways you can reduce that risk.

9. One hazard of the product is that inhaling it may cause drowsiness or dizziness. Identify 2 ways you can reduce that risk.

10. How many pages are in the complete SDS?

Safety Data Sheet



Revision Number: 003.0

Issue date: 10/18/2018

1. PRODUCT AND COMPANY IDENTIFICATION

Product name: LePage® PL200® Construction Adhesive
Product type: Adhesive
Restriction of Use: None identified
Company address: Henkel Canada Corporation
 Meadowpine Boulevard 2515
 Mississauga, Ontario L5N 6C3

IDH number: 1421928

Region: Canada

Contact information:
 Telephone: +1 (905) 814-6511
 MEDICAL EMERGENCY Phone: Poison Control Center
 1-877-671-4608 (toll free) or 1-303-592-1711
 TRANSPORT EMERGENCY Phone: CHEMTREC
 1-800-424-9300 (toll free) or 1-703-527-3887
 Internet: www.henkelna.com

2. HAZARDS IDENTIFICATION

EMERGENCY OVERVIEW

DANGER: HIGHLY FLAMMABLE LIQUID AND VAPOR.
 CAUSES SKIN IRRITATION.
 CAUSES SERIOUS EYE IRRITATION.
 MAY CAUSE DROWSINESS OR DIZZINESS.
 MAY CAUSE DAMAGE TO ORGANS THROUGH PROLONGED OR REPEATED EXPOSURE.

HAZARD CLASS	HAZARD CATEGORY
FLAMMABLE LIQUID	2
SKIN IRRITATION	2
EYE IRRITATION	2A
SPECIFIC TARGET ORGAN TOXICITY - SINGLE EXPOSURE	3
SPECIFIC TARGET ORGAN TOXICITY - REPEATED EXPOSURE	2

PICTOGRAM(S)



Precautionary Statements

Prevention: Keep away from heat, sparks, open flames, hot surfaces - no smoking. Keep container tightly closed. No release into water. Use explosion-proof equipment. Use non-sparking tools. Take action to prevent static discharges. Do not breathe vapors, mist, or spray. Wash affected area thoroughly after handling. Use only outdoors or in a well-ventilated area. Wear protective gloves, eye protection, and face protection.

Response: If on skin (or hair): Take off immediately all contaminated clothing. IF INHALED: Remove victim to fresh air and keep at rest in a position comfortable for breathing. Call a POISON CENTER or physician if you feel unwell. IF IN EYES: Rinse cautiously with water for several minutes. Remove contact lenses, if present and easy to do. Continue rinsing. Get medical attention if you feel unwell. If skin irritation occurs: Get medical attention. If eye irritation persists: Get medical attention. Take off contaminated clothing. In case of fire: Use foam, dry chemical or carbon dioxide to extinguish.

IDH number: 1421928

Product name: LePage® PL200® Construction Adhesive

HANDOUTS: SDS: Heavy Equipment Operator (5 pages)
Skill Builders: Key Words & Phrases, Tables & Lists

IN THE WORKPLACE: According to the WCB (Workers' Compensation Board), it is each worker's responsibility to learn about hazardous products they use and to follow safe work procedures. Detailed information about hazardous products is provided in Safety Data Sheets, usually called SDS.

PART 1: SDS standards are set by law. Every SDS must contain information on the following 16 sections.

1. **Product and Company Information:** Includes product name, what the product is used for, the chemical name, the name of the manufacturer or suppliers with contact information.
2. **Hazardous Identification:** The related hazard classifications (with pictograms) and the potential health effects of each hazard associated with the product.
3. **Composition/Ingredients:** Chemical and common names of hazardous ingredients.
4. **First aid measures:** Immediate treatment and information for medical professionals.
5. **Fire-fighting measures:** Suitable extinguishers and instructions to fire-fighters.
6. **Accidental release measures:** What to do if the product spills out of its container.
7. **Handling and Storage:** Precautions for safe handling.
8. **Exposure Controls/Personal Protection:** Guidelines for safe use and required personal protective equipment (PPE).
9. **Physical and Chemical Properties:** Information such as product colour and smell and details related to the product's chemicals' effects on health, safety and the environment.
10. **Stability and Reactivity:** What happens to the product if it comes into contact with another product.
11. **Toxicological information:** How health can be affected by short-term and long-term exposure to the product.
12. **Ecological information:** Information on the environmental impact of the product.
13. **Disposal Considerations:** Information on safe waste disposal including packaging.
14. **Transport Information:** Shipping information such as the shipping classification and the Transport Canada PIN (Product Information Number) for the whole product.
15. **Regulatory Information:** Safety, health and environmental regulations specific to the product.
16. **Other information:** Details of any changes to the SDS since the last revision.

On the job you will need to look up information in the SDS. You want to be efficient and start with the section that will most likely have the answers you are looking for.

- Decide which of the 16 sections of the SDS you would scan **first** to find the answer to each of the search questions below.
- Enter the **section number** of the section in the space provided.

Search Questions	Section (1-16)
1. What is the name of the product?	
2. What is the product made of?	
3. Where should the product be stored when not in use?	
4. What should you do if this product splashes in your eyes?	
5. Is the product made in Canada?	
6. If this product catches fire, how do you put it out?	
7. What sort of PPE should be worn when using this product?	
8. What should the product smell like?	
9. How can you dispose of leftover product?	
10. What are the US shipping codes for this product?	
11. What is the product used for?	
12. What hazards are associated with this product?	
13. What changes if any have been made since the last revision?	
14. Are there potential long term risks associated with using this product?	

PART 2: Locate the answers to the following questions in the SDS. Highlight the answers in the document or write them in the space provided below.

1. What is the product used for?

2. How many hazard types are identified? List them.

3. What 2 things does the pictogram indicate?

4. What should you do and not do if the product gets in your mouth?

5. What PPE should be used with the product?

6. Where can you find more information on possible side effects of exposure to the product?

7. What does Category 1C refer to?

8. How should the product be disposed of?

9. What is Canutec and why is their contact information included in the SDS? If you need help, use your phone to search for the answer.

SECTION 1. IDENTIFICATION

Product Identifier	Excalibur JW92
Recommended Use	Parts Washer Cleaner.
Manufacturer/	Excalibur Chemicals, 1120 McDonald St., Regina, SK, S4N 4X3, 306-569-2781,
Supplier Identifier	www.excaliburindustrial.com Canutec, (613) 996-6666, Collect calls accepted or dial 666 on your cellular.

SECTION 2. HAZARD IDENTIFICATION

Classified according to Canada's Hazardous Products Regulations (WHMIS 2015).

Classification

Acute toxicity (Oral) - Category 5; Skin corrosion - Category 1C; Eye irritation - Category 2A

Label Elements**Danger**

Causes severe skin burns and eye damage.

Wear protective gloves/protective clothing/eye protection/face protection.

IF SWALLOWED: Rinse mouth. Do NOT induce vomiting.

IF ON SKIN (or hair): Take off immediately all contaminated clothing. Rinse skin with water or shower.

IF INHALED: Remove person to fresh air and keep comfortable for breathing.

IF IN EYES: Rinse cautiously with water for several minutes. Remove contact lenses, if present and easy to do. Continue rinsing.

Call a POISON CENTRE or doctor if you feel unwell.

Dispose of contents and container in accordance with local, regional, national and international regulations.

SECTION 4. FIRST-AID MEASURES**Inhalation**

Move to fresh air. Keep at rest in a position comfortable for breathing.

Skin Contact

Take off contaminated clothing, shoes and leather goods (e.g. watchbands, belts). Quickly and gently blot or brush away excess chemical. Wash with plenty of water.

Eye Contact

Quickly and gently blot or brush chemical off the face. Rinse cautiously with water for several minutes. Remove contact lenses, if present and easy to do. Continue rinsing.

Ingestion

Rinse mouth with water. Drink 1 or 2 glasses of water. Never give anything by mouth if person is rapidly losing consciousness, or is unconscious or convulsing. Do not induce vomiting.

First-aid Comments

Get medical advice or attention if you feel unwell or are concerned.

Most Important Symptoms and Effects, Acute and Delayed

Review Section 11 (Toxicological) of this Safety Data Sheet.

Immediate Medical Attention and Special Treatment

Special Instructions: Treat Symptomatically.

Excalibur Industrial. (2016). Mirage JW92 SDS (Safety Data Sheet). Saskatoon, SK: Swish-Kemsol

This document has been modified. Sections 3 and 5-16 (inclusive) are not included here. This document is not an official version.

HANDOUTS: SDS: Welder (5 pages)

Skill Builders: Key Words & Phrases, Tables & Lists

IN THE WORKPLACE: According to the WCB (Workers' Compensation Board), it is each worker's responsibility to learn about hazardous products they use and to follow safe work procedures. Detailed information about hazardous products is provided in Safety Data Sheets, usually called SDS.

PART 1: SDS standards are set by law. Every SDS must contain information on the following 16 sections.

1. **Product and Company Information:** Includes product name, what the product is used for, the chemical name, the name of the manufacturer or suppliers with contact information.
2. **Hazardous Identification:** The related hazard classifications (with pictograms) and the potential health effects of each hazard associated with the product.
3. **Composition/Ingredients:** Chemical and common names of hazardous ingredients.
4. **First aid measures:** Immediate treatment and information for medical professionals.
5. **Fire-fighting measures:** Suitable extinguishers and instructions to fire-fighters.
6. **Accidental release measures:** What to do if the product spills out of its container.
7. **Handling and Storage:** Precautions for safe handling.
8. **Exposure Controls/Personal Protection:** Guidelines for safe use and required personal protective equipment (PPE).
9. **Physical and Chemical Properties:** Information such as product colour and smell and details related to the product's chemicals' effects on health, safety and the environment.
10. **Stability and Reactivity:** What happens to the product if it comes into contact with another product.
11. **Toxicological information:** How health can be affected by short-term and long-term exposure to the product.
12. **Ecological information:** Information on the environmental impact of the product.
13. **Disposal Considerations:** Information on safe waste disposal including packaging.
14. **Transport Information:** Shipping information such as the shipping classification and the Transport Canada PIN (Product Information Number) for the whole product.
15. **Regulatory Information:** Safety, health and environmental regulations specific to the product.
16. **Other information:** Details of any changes to the SDS since the last revision.

On the job you will need to look up information in the SDS. You want to be efficient and start with the section that will most likely have the answers you are looking for.

- Decide which of the 16 sections of the SDS you would scan **first** to find the answer to each of the search questions below.
- Enter the **section number** of the section in the space provided.

Search Questions	Section (1-16)
1. What is the name of the product?	
2. What is the product made of?	
3. Where should the product be stored when not in use?	
4. What should you do if this product splashes in your eyes?	
5. Is the product made in Canada?	
6. If this product catches fire, how do you put it out?	
7. What sort of PPE should be worn when using this product?	
8. What should the product smell like?	
9. How can you dispose of leftover product?	
10. What are the US shipping codes for this product?	
11. What is the product used for?	
12. What hazards are associated with this product?	
13. What changes if any have been made since the last revision?	
14. Are there potential long term risks associated with using this product?	

PART 2: Locate the answers to the following sections of the SDS. Highlight the answers or write the in the space provided below.

1. What is the product?

2. How many hazard types are identified? List them.

3. What day and month was the SDS last updated? How could it be written to make it clearer?

4. What should you do if the product, when hot, gets on your skin?

5. What component of the product causes the greatest health hazard? What disease can it cause?

6. Where can you find more information on what personal protection to use when handling spills?

7. How should the product be stored?

1. One hazard of the product is contact with its fumes. What part of the body can be affected by long-term overexposure to fumes? Identify 1 way you can reduce that risk.

2. Identify 2 ways the product can harm your eyes.

3. How many pages are in the complete SDS?

SAFETY DATA SHEET

Page: 1(6)
 SDS Number: CAN324-D
 Date Revised: 05/01/2014

1. PRODUCT AND COMPANY IDENTIFICATION

Product Name: ESAB OK® BARE STAINLESS STEEL WELDING ELECTRODES AND RODS
Application: Arc Welding
Classification: AWS A5.9
Supplier: ESAB GROUP CANADA, INC., 6010 Tomken Road, Mississauga, ON L5T 1X9
Telephone No.: (905) 670-0220, 1-877-935-3226
Web site: www.esab.ca

2. HAZARDS IDENTIFICATION

Emergency Overview: Metal wires or rods in varying colors. These products are normally not considered hazardous as shipped. Gloves should be worn when handling to prevent cuts and abrasions.

These products contain nickel, which is classified as toxic by prolonged inhalation, a skin sensitizer and a suspect carcinogen. In the form that nickel is present in these products it does not contribute to a hazard classification of the products.

Skin contact is normally no hazard but should be avoided to prevent possible allergic reactions.

Persons with a pacemaker should not go near welding or cutting operations until they have consulted their doctor and obtained information from the manufacturer of the device.

When these products are used in a welding process, the most important hazards are heat, radiation, electric shock and welding fumes.

Heat: Spatter and melting metal can cause burn injuries and start fires.

Radiation: Arc rays can severely damage

eyes or skin. Electricity: Electric shock can kill.

Fumes: Overexposure to welding fumes may result in symptoms like metal fume fever, dizziness, nausea, dryness or irritation of the nose, throat or eyes. Chronic overexposure to welding fumes may affect pulmonary function. Prolonged inhalation of nickel and chromium compounds above safe exposure limits can cause cancer. Overexposure to manganese and manganese compounds above safe exposure limits can cause irreversible damage to the central nervous system, including the brain, symptoms of which may include slurred speech, lethargy, tremor, muscular weakness, psychological disturbances and spastic gait.

4. FIRST AID MEASURES

Inhalation: If breathing has stopped, perform artificial respiration and obtain medical assistance immediately! If breathing is difficult, provide fresh air and call physician.

Eye contact: For radiation burns due to arc flash, see physician. To remove dusts or fumes flush with water for at least fifteen minutes. If irritation persists, obtain medical assistance.

Skin contact: For skin burns from arc radiation, promptly flush with cold water. Get medical attention for burns or irritations that persist. To remove dust or particles wash with mild soap and water.

Electric shock: Disconnect and turn off the power. Use a nonconductive material to pull victim away from contact with live parts or wires. If not breathing, begin artificial respiration, preferably mouth-to-mouth. If no detectable pulse, begin Cardio Pulmonary Resuscitation (CPR). Immediately call a physician.

General: Move to fresh air and call for medical aid.

5. FIRE FIGHTING MEASURES

No specific recommendations for welding consumables. Welding arcs and sparks can ignite combustible and flammable materials. Use the extinguishing media recommended for the burning materials and fire situation. Wear self-contained breathing apparatus as fumes or vapors may be harmful.

6. ACCIDENTAL RELEASE MEASURES

Solid objects may be picked up and placed into a container. Liquids or pastes should be scooped up and placed into a container. Wear proper protective equipment while handling these materials. Do not discard as refuse.

Personal precautions: refer to Section 8.

Environmental precautions: refer to Section 13.

7. HANDLING AND STORAGE

Handling:

Handle with care to avoid stings and cuts. Wear gloves when handling welding consumables. Avoid exposure to dust. Do not ingest. Some individuals can develop an allergic reaction to certain materials.

Retain all warning and identity labels.

Storage:

Keep separate from chemical substances like acids and strong bases, which could cause chemical reactions.

ESAB (2014). ESAB OK® bare stainless steel welding electrodes and rods. (Safety Data Sheet).

<https://www.esab.ca/ca/en/support/documentation/upload/can324.pdf>

This document has been modified. Sections 3 and 8-16 (inclusive) are not included here. This document is not an official version.



Document Use Answer Keys



ANSWER KEY: Apprenticeship Completion
Skill Builders: Key Words & Phrases, Flowcharts

1. If the total number of survey respondents was 28,469, how many people discontinued their program during 2011- 2013? **12,099 (42.5% of 28,469)**
2. What percentage of those apprentices who discontinued their program went on to complete in 2015? How many people is that? **5% completed in 2015. 604 people.**
3. What period of time has elapsed between the pie charts? **2 years (2013-2015)**
4. What data is shown on each of the X and Y axes in the bar chart?
X: percentage of responders, Y: reasons given for discontinuing.
5. The values in the bar chart do not add up to 100 percent. What is the approximate percentage of missing values in the bar graph? Why are the missing values excluded from the bar graph? **The missing values represent approximately 11% of the total reasons discontinuers do not complete apprenticeship training. Missing values represent other unspecified reasons for discontinuers not completing apprenticeship training and are likely too small to report on a bar chart (each reason being less than 1%).**
6. Redraw the bar graph as a pie chart. Represent all reasons of more than 5% by their own section. Represent all other reasons including any missing values as a single section labelled "other". Label the chart section including text and percentages. Use whole numbers for all values.
5 reasons are represented as more than 5%

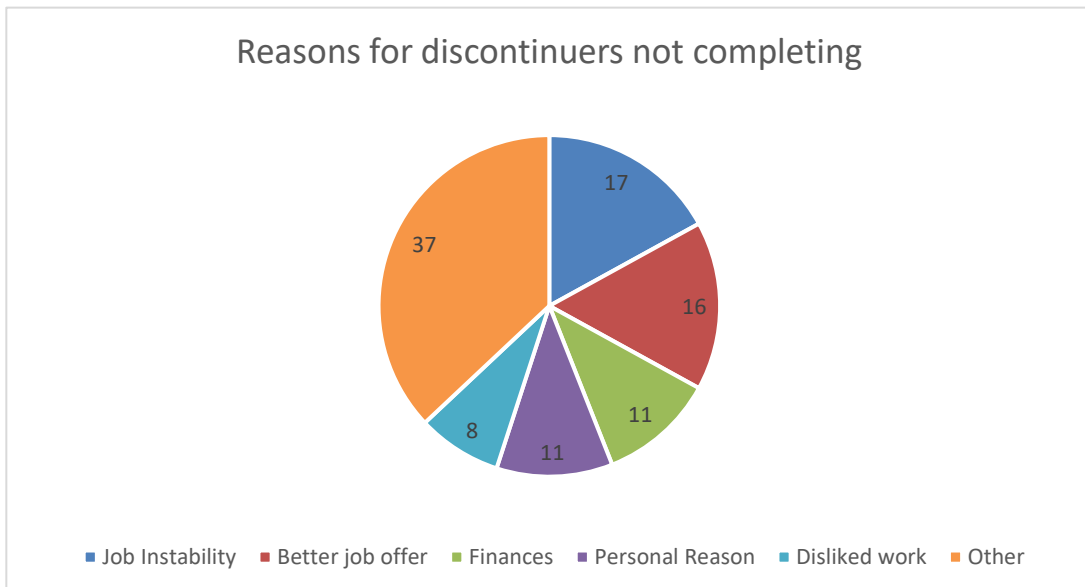

ANSWER KEY: Flowchart: Backhoe Operation Skill Builder: Flowcharts

Answers may vary but must be logical and contain proper usage of symbols to be considered correct.

Note: Possible decision points include:

- Need to replace parts
- Need to top up fluids
- Need to adjust controls
- Need to move backhoe to stabilize
- Need to adjust boom and swing lock

An example flowchart is shown for your reference.

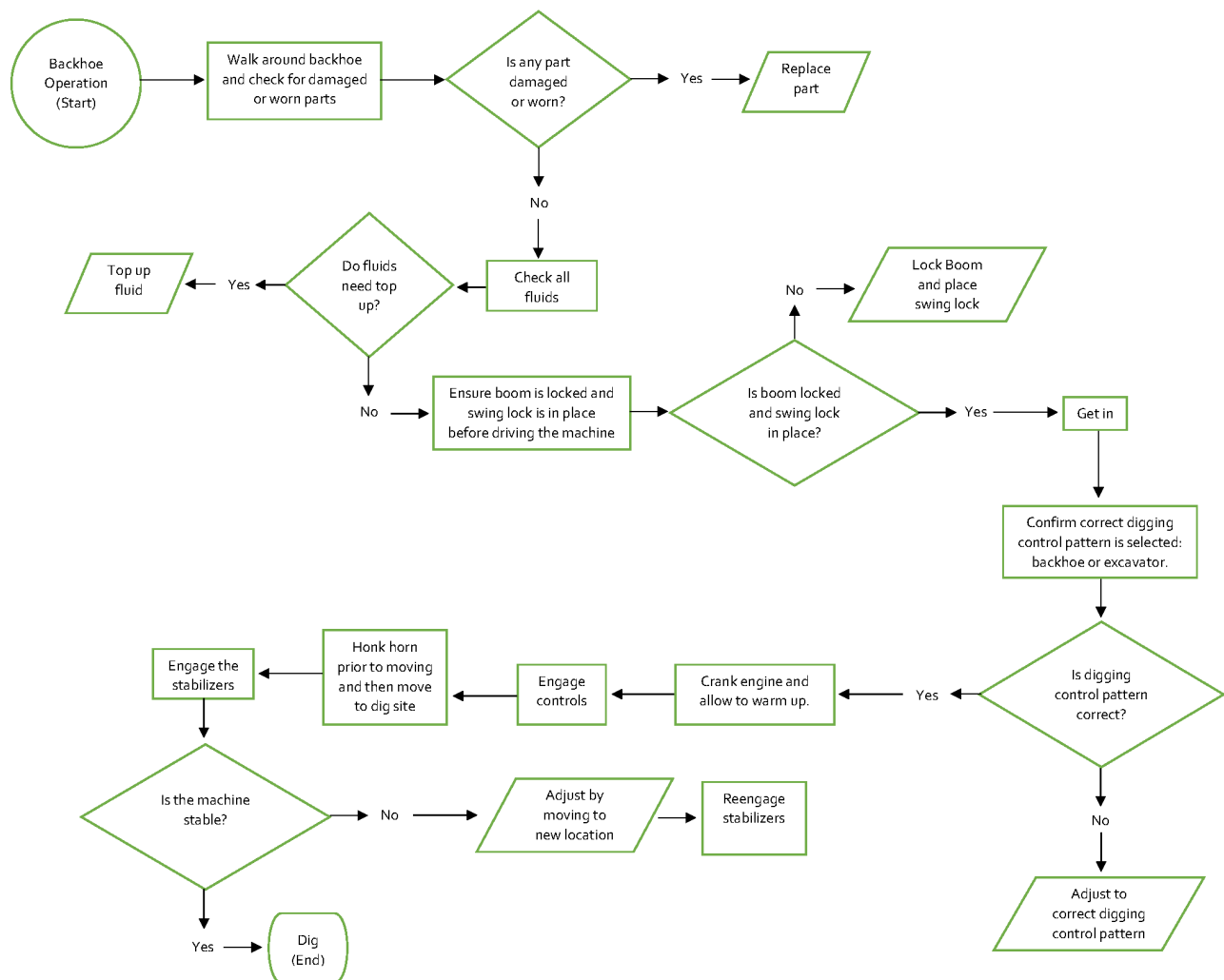

ANSWER KEY: Hazard Assessment
Skill Builders: Key Words & Phrases, Entry Forms

1. What date format is required? **D/M/Y**
2. Who should the completed form be given to? **Supervisor**
3. For each identified hazard, identify an appropriate control from the options. **Possible answers include the following. Other answers should be considered correct if the pre/apprentice can provide a direct link.**
 - a) Confined space: **Confined Space Entry Procedures**
 - b) Animal droppings: **Respirator**
 - c) Unsafe equipment: **There is no control provided. A note needs to be made in the comment section.**
Accept Lockout tag out procedure. Procedure may be required when reporting unsafe equipment or to indicate that machinery/equipment is non-operational due to unsafe condition and/or imminent repair.
 - d) Sharp objects: **Protective gloves**
4. Complete the assessment form to identify any hazards in the room you are currently working in (or an outside space or class shop if available). Work with a partner or in a small group. Compare your results with another team who assessed the same space.

Answers will vary depending on the space assessed. The resulting discussion should provide answers to the following questions:

- a) **Was it possible to complete all sections of the form?**
- b) **Were the hazards correctly identified?**
- c) **Is there a plan for controlling the hazard in place?**

ANSWER KEY: Incident Report
Skill Builders: Key Words & Phrases, Entry Forms

Answers may vary but the following information should be included. Have pre/apprentices compare their completed reports with partners.

INCIDENT REPORT

GENERAL INFORMATION			
Name of Person Completing Report:			
Name of Injured or Affected Person:			<input checked="" type="checkbox"/> Employee <input type="checkbox"/> Customer
Incident Date: June 2 /17	Time of Occurrence:	Facility:	
Department:		Location (specific): Wakaw	
INCIDENT TYPE			
<input checked="" type="checkbox"/> Slip/Trip/Fall	<input type="checkbox"/> Cut	<input type="checkbox"/> Property Damage	
<input type="checkbox"/> Personal Illness	<input type="checkbox"/> Struck by	<input type="checkbox"/> Property Theft	
<input type="checkbox"/> Ergonomic	<input checked="" type="checkbox"/> Caught in	<input type="checkbox"/> Fire / Flood Hazardous Spill / Leak	
<input type="checkbox"/> Inappropriate Conduct	<input type="checkbox"/> Chemical Exposure	<input type="checkbox"/> Other:	
<input type="checkbox"/> Violence / Threat / Harassment	<input type="checkbox"/> Biohazard Exposure		
OTHER PERSONNEL INVOLVED AND WITNESSES			
	Name	Department	Phone / Contact
1	Bradley Davidson	Supervisor	
2			
3			
BASIC DESCRIPTION OF OCCURRENCE			
<div style="border: 1px solid black; padding: 10px; margin: 10px auto; width: 80%;"> <ol style="list-style-type: none"> 1. Worker was feeding gravel into loader. 2. Machine was switched off and supervisor ordered work to clear. 3. Machine was turned back on while worker still clearing. 4. Worker traveled through the conveyor. 5. Worker then fell 12 feet. </div> <p style="text-align: right;"><input type="checkbox"/> See Attached Documentation</p>			
FIRST AID / MEDICAL RESPONSE			
First Aid Provided: <input type="checkbox"/> Yes <input type="checkbox"/> No		Ambulance Involved: <input checked="" type="checkbox"/> Yes <input type="checkbox"/> No	
First Aider:		Sent to Hospital: <input checked="" type="checkbox"/> Yes <input type="checkbox"/> No	
<input type="checkbox"/> Emergency First Aider <input type="checkbox"/> Standard First Aider		Medical Facility:	
<input type="checkbox"/> Security <input type="checkbox"/> Other:		Time Off Site:	
Details of the first aid that was provided:			

SEE OVER

Rev. 201708

Incident Report

CAUSES THAT LED TO THE INCIDENT

- 1. Supervisor did not follow procedure.
- 2. Supervisor did not perform visual check before restarting machine.

ACTIONS TAKEN TO PREVENT RECURRENCE

- (Not mentioned in the article but assumed following safe work practices)
- 1. All workers were refreshed on correct procedures.
 - 2. Subsequent court action and fine would be a deterrent.
 - 3. Supervisor no longer with company.

REPORTED TO

Authority	Name	Date	Case / Ref #:
Supervisor / Director / Dean			N/A
Human Resources			N/A
Workers' Compensation Board			
Police			

REPORT COMPLETED BY

Name	Position	Date	Time
Enter own name and sign			

SIGNATURE:

SENIOR MANAGEMENT REVIEW

Name	Position	Date

SIGNATURE:

Send completed original form to Occupational Health & Safety
by interoffice mail or email to safety@organization.ca

ANSWER KEY: Invoice 3
Skill Builders: Entry Forms, Tables

1. What is the invoice number? **9-23**
2. When was the invoice issued? **October 23, 2018**
3. What is the last date payment should be made?
November 22, 2018 (30 days from October 23)
4. What 3 ways can payment be made? **Credit card, billed to account, or by cheque**
5. If paying by cheque, what name should the cheque be issued to? **RCP Contractors**
6. What is the full name of the person who placed the order? **Chris Adam**
7. What is the product number? **3127X3**
8. What is the % of tax being charged? **13%**
9. If the apprentice's time is billed out at \$25 an hour, how much of the total labour charge is for the journeyperson's time? **\$1,120.00**
10. The company offers a discount to educational institutions on invoices over \$8,000 before tax. Is the university eligible for the discount? How do you know?
No. It is an educational institution but before tax the invoice is less than \$8,000.

ANSWER KEY: Line Drawings
Skill Builders: Technical Drawings

1. See below.

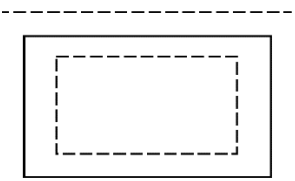
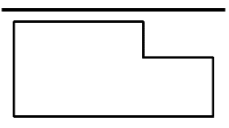
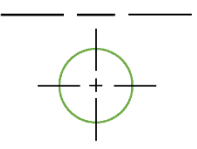
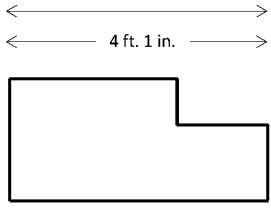
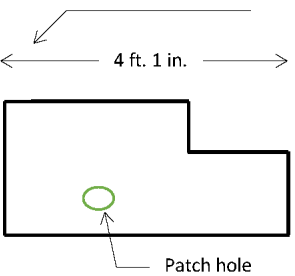
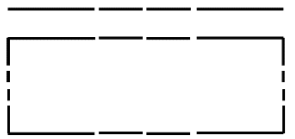
Line #	Example	Def.	Definition
1		C	Hidden line: Short dashed lines use to show nonvisible surfaces. Usually shows as medium thickness.
2		G	Object or Visible line: Thick dark line use to show outline of an object, visible edges and surfaces.
3		A	Centre Line: Long and short dash lines. Usually indicates centre of holes, circles and arcs. Line is thin and dark.
4		B	Dimension Line: Thin and dark lines use to show the size (span) of an object with a numeric value. Usually terminates with arrowheads or tick markings. Often shown with a break in the middle where the measurement will be noted.
5		E	Leader Line: Medium line with arrowhead to show notes or to label for size or special information about a feature.
6		D	Property Line: Long dashes alternating with two short dashes. This line is used to show the actual legal line of the property.

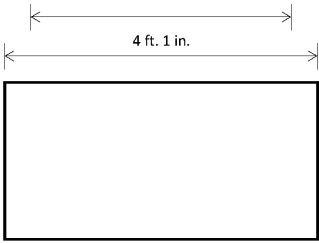
7		F	<p>Extension Line: Thin and dark line used to show the start and end of a dimension. The extension line does not touch the object and it ends just past the head of the arrow.</p>
---	---	---	---

2. Answers will vary.

ANSWER KEY: Log Book: HEO
Skill Builder: Entry Forms

- Under the subheading "From", in what order should the date information be entered?
Day, month, year
- In what month was the excavator entry completed? **September.**
- The period of operation for the backhoe was incorrectly recorded and actually ended on June 11, 2015. Correct the entry using the boxes provided below.

	Type of Machine	Date			Date			Period of Operation		
Page	Model and Size	From			To			days/weeks/months		
3	Backhoe, Caterpillar	15	09	14	11	06	15	6	3	7

- Enter the correct number of months to complete entry 5. **5**
- Complete the "To" line for entry 6. **18**
- On which machine did the operator complete the greatest number of days?
Wheel skidder.
- On which machine did the operator complete the fewest number of days?
Loader.
- Add a 7th entry using the following information:
 - Same equipment as first entry
 - Started work 14 days after entry 6 completed
 - Worked 6 months and 3 days

6	Wheel skidder, Hitachi	07	05	17	01	08	18	4	3	14
7	Excavator, Hitachi	15	08	18	18	02	19	3	0	6

ANSWER KEY: Maintenance Schedule: Sprinkler
Skill Builder: Entry Forms, Tables & Lists

1. Which tasks need to be performed 4 times a year?
Conduct main drain tests and check general condition of standpipe systems.
2. How often should dry trip tests be performed? **Once a year.**
3. How often should wet trip tests be performed? **Every 3 years.**
4. Which sprinkler tests relate to water flow?
 1. **Conduct flow test of open sprinklers**
 2. **Perform water flow tests**
 3. **Perform fire pump flow test**
5. How often should alarms be inspected? **Water flow alarms should be inspected monthly.**
6. What types of valves need to be inspected? **Check valves, dry pipe valves, pressure regulating, and altitude valves.**
7. **Exact days on calendar may vary but should clearly show which tasks need to be performed weekly and monthly.**
 - A. **Check water level in tanks (weekly)**
 - B. **Start fire pumps (weekly)**
 - C. **Check air pressure (weekly)**
 - D. **Inspect and test controllers (do not include)**
 - E. **Inspect valves for open position (monthly)**

Sun	Mon	Tue	Wed	Thu	Fri	Sat
					1 E	2
3 A	4 B	5 C	6	7	8	9
10 A	11 B	12 C	13	14	15	16
17 A	18 B	19 C	20	21	22	23
24 A	25 B	26 C	27	28		

8. Assuming the year starts January 1, what additional tasks would have to be completed in March? **Conduct main drain tests and check general condition of standpipe systems.**

ANSWER KEY: Mileage Log

Skill Builder: Entry Forms, Tables & Lists

Mileage Log						
Employee name	Alex Wu		Rate per km	.56	Do not write here:	
ID	0015822		For period	13/09/19 --- 19/09/19		
Authorized by	LG		Total mileage	112 km		
Authorized on	21/09/19		Total reimbursement	\$62.72		
Date	Starting Location	Destination	Odometer start	Odometer end	Mileage	Reimbursement
13/09/19	Office	Site B	23111	23128	17	9.52
15/09/19	Warehouse	Site A (return trip)	23156	23200	44	24.64
17/09/19	Office	Warehouse	23209	23221	12	6.72
18/09/19	Site A	Warehouse	23241	23263	22	12.32
19/09/19	Site B	Office	23277	23294	17	9.52

ANSWER KEY: Project Schedule
Skill Builder: Key Words & Phrases, Charts & Graphs

1. What is the project completion date? **Thursday June 27.**
2. Who is responsible for the wiring and how many days will they need? **SR is responsible and the wiring will take 6 days.**
3. Who is responsible for the greatest number of project days? How many? **WM is responsible for 13 days.**
4. What tasks must be completed before the materials are purchased? **Design and engineer and obtain permits.**
5. If the inspection is moved up a week, what task(s) definitely need to be rescheduled? What additional task(s) may need to be rescheduled? **Definitely install AC and install PV modules. Maybe install DC wiring.**
6. How many work days can the procurement of the PV modules be delayed without impacting the schedule? **3 work days (to have them arrive the day before they are installed).**

ANSWER KEY: Product Recall: Chainsaw
Skill Builders: Key Words & Phrases, Scanning, Tables & Lists

1. When was the recall issued? **July 19, 2018**
2. How many Makita DCS products are included in the recall? **4**
3. How many of the affected units were sold in Canada? **2,503 units**
4. Is a Dolmar PS7900 purchased in January 2002 affected? Why or why not?
No. The affected products were not sold in Canada until April 2002.
5. What is another word for laceration? **Cut**
6. What are the 3 classes of chainsaw included in the recall? **64, 73, and 79 cc classes**
7. What is the hazard and the related danger in using the recalled chainsaws?
Hazard: The automatic chain brake does not easily engage when the saw kicks back Danger: That a user may come in contact with the chain and be cut by it
8. What should a person who owns a chainsaw in the list do immediately and later?
Immediately stop using it. Later take to a Makita Canada Factory Service Centre.
9. Can the chainsaws be repaired? At what cost? **Yes. Repair is free.**
10. What company manufactures the Makita chainsaws? **Dolmar GMBH, Makita Engineering**
11. The information in a product recall alert is divided into 3 sections. What would you title each section?
Answer may vary but suggested answers include: Section 1: Recall summary or Important information Section 2: Affected products Section 3: What you should do
12. Answers will vary depending on the product selected.

ANSWER KEY: Product Recall: Digital Clamp Meters
Skill Builders: Key Words & Phrases, Scanning, Tables & Lists

1. When was the recall issued? **May 25, 2017**
2. How many meter types are included in the recall? **5**
3. How many of the affected units were sold in Canada? **Approximately 21 units**
4. Is an EX655 purchased in April 2016 affected? Why or why not?
Yes. The affected products were sold in Canada between January 2016 and April 2017.
5. What years were the recalled meters distributed? **2016 and 2017**
6. Which Extech meters are not included in the recall?
Those that have a serial number ending in an "A"
7. What is the hazard and the related danger in using the recalled meters?
Hazard: The screws can come loose which can fail to give accurate voltage readings Danger: That electrocution can occur
8. What should a person who owns a meter do right away?
Immediately stop using it and contact Extech for an exchange.
9. Can a consumer have the meters repaired? **No. They can be replaced.**
10. What company manufactures the meters? **Uni-Trend Technology Limited.**
11. The information in a product recall alert is divided into 3 sections. What would you title each section?
Answer may vary but suggested answers include: Section 1: Recall summary or Important information Section 2: Affected products Section 3: What you should do
12. Answers will vary depending on the product selected.

ANSWER KEY: Product Recall: Torch Handles
Skill Builders: Key Words & Phrases, Scanning, Tables & Lists

1. When was the recall issued? **July 31, 2014**
2. What brand names was the product sold under? **Lincoln Electric Company and Harris Products Group.**
3. How many of the affected units were sold in Canada? **Approximately 350 units**
4. Is a WELD-HDL 18-5 purchased in December 2014 affected? Why or why not?
No. The affected products were sold in Canada only until May 2014.
5. What does the model number prefix 440 indicate? **That the product is sold as part of a kit.**
6. Which Harris handles are not included in the recall?
Those that are marked with a "o" above the word "Harris" and to the right of the rivet head.
7. What is the hazard and the related danger in using the recalled product?
Hazard: The torch handles can leak oxygen or fuel
Danger: Fire can occur
8. What should a consumer do both right away and later?
Immediately stop using the recalled torch handle. Later, contact Harris for a replacement.
9. What 2 ways is the product sold? **Individually and as part of a kit or outfit.**
10. Where and by what company is the product manufactured?
Harris Calorific International in Dzieronow, Poland.
11. The information in a product recall alert is divided into 3 sections. What would you title each section?
Answer may vary but suggested answers include: Section 1: Recall summary or Important information Section 2: Affected products Section 3: What you should do
12. Answers will vary depending on the product selected.

ANSWER KEY: Product Recall: Hot Water Boiler
Skill Builders: Key Words & Phrases, Scanning, Tables & Lists

1. How long after the posting date was the recall information modified? **10 days later**
2. What 2 conditions can cause the seal to deteriorate? **Excessive use and/or improper installation**
3. How many of the affected units were sold in Canada? **Approximately 7359 units**
4. Is a model Tft155 purchased in October 2018 affected? Why or why not?
No. The affected products were sold in Canada only until January 2018.
5. What is the common UPC prefix for all of the recalled boilers? **First 8 digits: 62823373**
6. Which information is different between the Canadian and American reports?
Reports of seal deterioration: CAN: 2, USA: 1
Reports of emissions: CAN: 1, USA: 0 Reports of injuries is the same (none)
7. What is the hazard and the related danger in using the recalled product?
Hazard: Grommet seal may deteriorate
Danger: Exposure to low levels of carbon monoxide
8. What should a consumer do both right away and later?
Immediately stop using the recalled boilers. Later, contact their installer to have an upgrade kit installed.
9. Who can install the upgrade kit? **Only certified installers.**
10. Where and by what company is the product distributed?
NY Thermal in Saint John, New Brunswick, Canada
11. The information in a product recall alert is divided into 3 sections. What would you title each section?
Answer may vary but suggested answers include: Section 1: Recall summary or Important information Section 2: Affected products Section 3: What you should do
12. Answers will vary depending on the product selected.

ANSWER KEY: SDS: Auto Service Technician
 Skill Builder: Key Words & Phrases, Tables & Lists

PART 1.

Search Questions	Section (1-16)
1. What is the name of the product?	1
2. What is the product made of?	3
3. Where should the product be stored when not in use?	7
4. What should you do if this product splashes in your eyes?	4
5. Is the product made in Canada?	1
6. If this product catches fire, how do you put it out?	5
7. What sort of PPE should be worn when using this product?	8
8. What should the product smell like?	9
9. How can you dispose of leftover product?	13
10. What are the US shipping codes for this product?	14
11. What is the product used for?	1
12. What hazards are associated with this product?	2
13. What changes if any have been made since the last revision?	16
14. Are there potential long term risks associated with using this product?	11

PART 2.

1. What is the name of the product? **Integrally Molded Brake Pad**
2. What is the phone number to call in a medical emergency? **(519) 763-9000**
3. What month and year was the SDS last issued? **August 2015**
4. What should you do if the product gets in your eyes?
**Remove any contact lenses.
Immediately and continuously flush eyes with water for 15 minutes. If irritation persists, seek medical attention.**
5. Where can you find information on what protective equipment to use? **Section 8**
6. When should a respirator be used as part of the PPE? **If airborne dust is generated.**
7. How should the product be stored? Why?
In a dry area. Product could rust if in contact with moisture.
8. Identify 2 recommended actions for how to clean up the product and 1 action that is not recommended.
Recommended: Use a HEPA vacuum or wet clean up Not recommended: Do not use compressed air
9. What evidence is there that dust from the product may pose a health risk?
**SDS advises minimize dust generation and to use adequate ventilation if dust is generated.
SDS advises not to use compressed air to contain the product (would blow any dust).**
10. When should calling for medical help be the first response?
If the product is ingested (eaten or swallowed).

ANSWER KEY: SDS: Carpenter**Skill Builders: Key Words & Phrases, Tables & Lists****PART 1.**

Search Questions	Section (1-16)
1. What is the name of the product?	1
2. What is the product made of?	3
3. Where should the product be stored when not in use?	7
4. What should you do if this product splashes in your eyes?	4
5. Is the product made in Canada?	1
6. If this product catches fire, how do you put it out?	5
7. What sort of PPE should be worn when using this product?	8
8. What should the product smell like?	9
9. How can you dispose of leftover product?	13
10. What are the US shipping codes for this product?	14
11. What is the product used for?	1
12. What hazards are associated with this product?	2
13. What changes if any have been made since the last revision?	16
14. Are there potential long term risks associated with using this product?	11

PART 2.

1. What is the name of the product? **LePage PL200 Construction Adhesive**
2. What is the phone number to call in a medical emergency? **1-877-671-4608 or 1-303- 592-1711**
3. What month and year was the SDS last issued? **December 2018**
4. What should you do if the product gets in your eyes?
Rinse cautiously with water for several minutes.
Remove contact lenses if present and easy to do.
Continue rinsing.
If eye irritation persists: Get medical attention.
5. How can you prevent the product getting in your eyes? **Wear eye protection.**
6. What 3 types of personal protection equipment should be worn when using the product?
Protective gloves, eye protection, and face protection.
7. After the product container is closed, identify 3 precautions for how it should be stored.
In a well-ventilated place.
Keep cool.
Store locked up.
8. One hazard of the product is that it is highly flammable. Identify 2 ways you can reduce that risk. **Accept any two of the following:**
 1. **Keep away from heat, sparks, open flames, hot surfaces – no smoking.**
 2. **Use explosion-proof equipment.**
 3. **Use only non-sparking tools.**
 4. **Take precautionary measures against static discharge.**
9. One hazard of the product is that inhaling it may cause drowsiness or dizziness. Identify 2 ways you can reduce that risk. **Accept any two of the following:**
 1. **Keep container tightly closed.**
 2. **Avoid breathing vapours, mist or spray.**
 3. **Use only outdoors or in well-ventilated area.**
10. How many pages are in the complete SDS? **8**

ANSWER KEY: SDS: Heavy Equipment Operator
Skill Builders: Key Words & Phrases, Tables & Lists

PART 1.

Search Questions	Section (1-16)
1. What is the name of the product?	1
2. What is the product made of?	3
3. Where should the product be stored when not in use?	7
4. What should you do if this product splashes in your eyes?	4
5. Is the product made in Canada?	1
6. If this product catches fire, how do you put it out?	5
7. What sort of PPE should be worn when using this product?	8
8. What should the product smell like?	9
9. How can you dispose of leftover product?	13
10. What are the US shipping codes for this product?	14
11. What is the product used for?	1
12. What hazards are associated with this product?	2
13. What changes if any have been made since the last revision?	16
14. Are there potential long term risks associated with using this product?	11

PART 2.

1. What is the product used for? **Parts washer cleaner**
2. How many hazard types are identified? List them. **3. Acute toxicity, skin corrosion, and eye irritation**
3. What 2 things does the pictogram indicate?
The product is corrosive to metal.
The product is corrosive to skin.
4. What should you do and not do if the product gets in your mouth?
Do: rinse mouth and drink water Do
not: induce vomiting
5. What PPE should be used with the product? **Gloves, protective clothing, eye protection, and face protection**
6. Where can you find more information on possible side effects of exposure to the product? **Section 11**
7. What does Category 1C refer to? **Skin corrosion**
8. How should the product be disposed of?
In accordance with local, regional, national and international regulations
9. What is Canutec and why is their contact information included in the SDS? If you need help, use your phone to search for the answer.
Canutec is the Canadian Transport Emergency Centre. Their information is included because they operate a 24-hour emergency hotline for immediate advice and recommended actions related to the transport of hazardous products.

ANSWER KEY: SDS: Welder
Skill Builders: Key Words & Phrases, Tables & Lists

PART 1.

Search Questions	Section (1-16)
1. What is the name of the product?	1
2. What is the product made of?	3
3. Where should the product be stored when not in use?	7
4. What should you do if this product splashes in your eyes?	4
5. Is the product made in Canada?	1
6. If this product catches fire, how do you put it out?	5
7. What sort of PPE should be worn when using this product?	8
8. What should the product smell like?	9
9. How can you dispose of leftover product?	13
10. What are the US shipping codes for this product?	14
11. What is the product used for?	1
12. What hazards are associated with this product?	2
13. What changes if any have been made since the last revision?	16
14. Are there potential long term risks associated with using this product?	11

PART 2.

1. What is the product? **Welding electrodes and rods**
2. How many hazard types are identified? List them. **4. Heat, radiation, electricity and fumes**
3. What day and month was the SDS last updated? How could it be written to make it clearer?
Either May 1 or Jan 5.
Would be clearer if month was written as a word. NOTE:
Canadian standard is YYYY-MM-DD.
4. What should you do if the product, when hot, gets on your skin?
Promptly flush with cold water.
Get medical attention for burns or irritation that persists.
Remove dust and particles by washing with mild soap and water.
5. What component of the product causes the greatest health hazard? What disease can it cause?
Nickel. Cancer.
6. Where can you find more information on what personal protection to use when handling spills? **Section 8**
7. How should the product be stored?
Separate from chemical substances like acids and strong bases
8. One hazard of the product is contact with its fumes. What part of the body can be affected by long-term overexposure to fumes? Identify 1 way you can reduce that risk. **Lungs.**
Reduce exposure and/or wear proper PPE (for example, a respirator)
9. Identify 2 ways the product can harm your eyes.
1. Radiation burn due to arc flashing
2. Dust or fumes in the eyes
10. How many pages are in the complete SDS? **6**



Numeracy



HANDOUT: Door Order Sheet (2 pages)
Skill Builders: Entry Forms, Technical Drawings

IN THE WORKPLACE: Contractors, estimators, builders and tradespersons must be able to accurately interpret a wide range of documents including technical drawings and order forms.

Use the **Door Order Sheet** on the next page to locate the answers to the following questions.

1. What 2 purposes is the form used for?

2. What measurement system does the form use?

3. How many gauges of metal door are always available? What are they?

4. What do the abbreviations PO and QUAN stand for?

5. In addition to hinges, latch, edge seam and prime, what 3 features of door construction must be selected to complete an order?

6. Measure all the doorways in the room you are in. Enter that information in the form in the columns: quan, net width, net length and thickness.

7. Draw and label a door using the dimensions from one of the doors you just measured. Include height, width, and depth measurements. Show hinge locations, door knob, and any windows in the door. Use the graph paper provided and the scale 1 square = 3 inches.

BV METAL FRAMES		DOOR SHEET		<input type="checkbox"/> QUOTE	<input type="checkbox"/> ORDER
PHONE # (403) 455-9161		FAX # (403) 455-9152		PAGE _____	OF _____
CUSTOMER:		SHIPPING: <input type="checkbox"/> STANDARD <input type="checkbox"/> QUICK SHIP <input type="checkbox"/> OTHER			
ORDERED BY:		SHIP DATE NEEDED:			
DATE ORDERED:		SHIPPING ADDRESS:			
PO #					
QUOTE #					
CUSTOMER PHONE #					
ALL DIMENSIONS ARE IN INCHES AND ARE EXACT		CONTACT & PHONE #			
NOTE: STANDARD IS 18 GA A-40					

METAL:	GAUGE: <input type="checkbox"/> 18 <input type="checkbox"/> 16 <input type="checkbox"/> 14 (CALL FOR AVAILABILITY)	MATERIAL: <input type="checkbox"/> A-40 <input type="checkbox"/> A-60 <input type="checkbox"/> G-90
---------------	--	---

CORE:	<input type="checkbox"/> HC <input type="checkbox"/> POLY <input type="checkbox"/> SS <input type="checkbox"/> SSTF <input type="checkbox"/> T-650 <input type="checkbox"/> LEAD LINED	PRIME	YES	NO
HINGES:	<input type="checkbox"/> 4 ½" <input type="checkbox"/> 4 ½" HW <input type="checkbox"/> 5" <input type="checkbox"/> 5" HW <input type="checkbox"/> OTHER	BACKSET:		
LATCH:	<input type="checkbox"/> 161 <input type="checkbox"/> 161 W/TB <input type="checkbox"/> 86 EDGE <input type="checkbox"/> ML <input type="checkbox"/> BLANK <input type="checkbox"/> DB	BACKSET:		
	<input type="checkbox"/> FB <input type="checkbox"/> REINF SVR <input type="checkbox"/> CON VR <input type="checkbox"/> ASA <input type="checkbox"/> OTHER			
EDGE SEAM:	<input type="checkbox"/> VISABLE SEAM <input type="checkbox"/> SEAMLESS <input type="checkbox"/> TOP CAP <input type="checkbox"/> BOTTOM CAP			

MISC NOTES:	ALL TEMPLATES MUST BE INCLUDED
	TEMPLATES:

QUAN	UC	TAG	NET WIDTH		NET LENGTH		THICK	HAND	LABEL	CLOSER REINF	OTHER
			FT	INCH	FT	INCH					

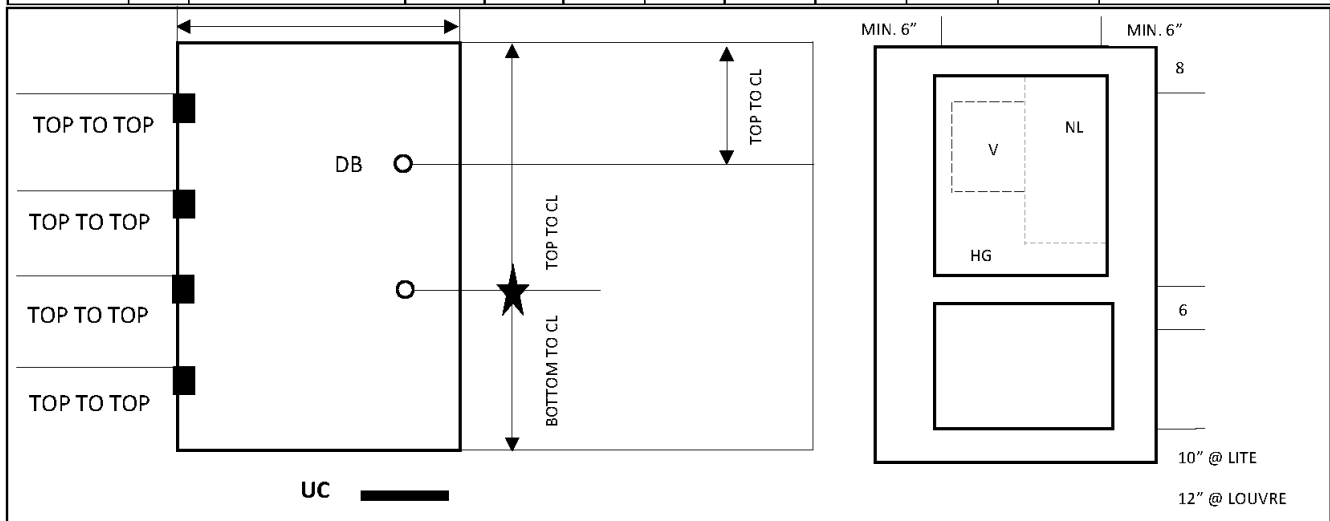

Ref: Bow Valley College. (2020). Metal door frame order sheet. [Form]. Calgary, Canada: Author.

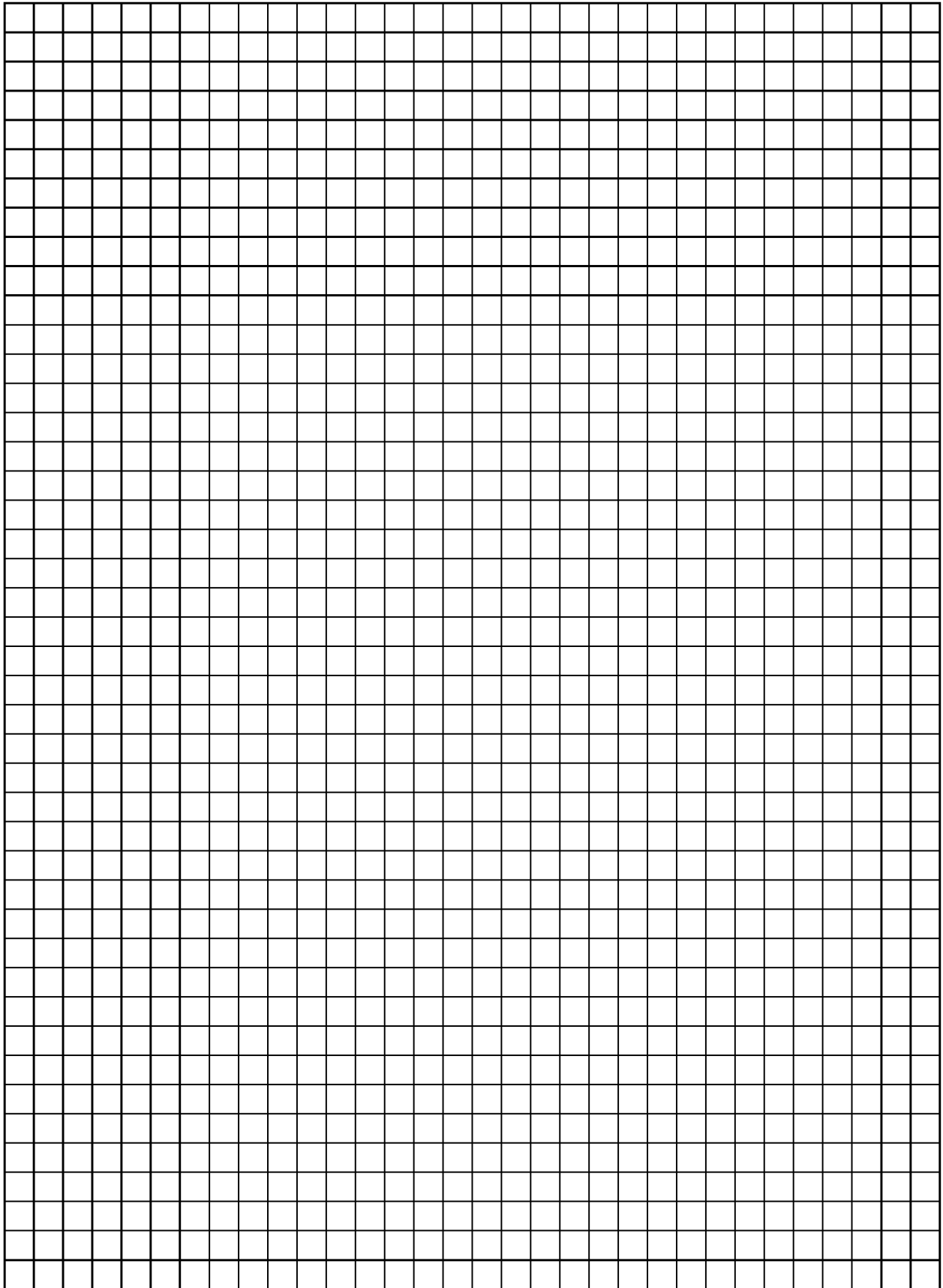

HANDOUT: Heating Systems (3 pages)

Skill Builders: Key Words & Phrases, Charts & Graphs, Tables & Lists

IN THE WORKPLACE: The actual costs of different systems, such as electrical and heating, involve not just installation but operating and replacement over time. Understanding those complex costs is critical to ensuring overall project costs are accurate.

Refer to the **Heating Systems** article to locate the answers to the following questions.

1. What is the main focus of the article?

2. What systems are being compared?

3. What specific features are being compared?

4. Calculate for each system the total cost after each of the following:

- a. 1 year

- b. 10 years

- c. 20 years

5. Organize the information in the article as a table.

6. Organize the information in the article as a bar chart.

7. Which layout do you think is easiest to understand? Why?

Heating Systems: What's Best?

There are many things to consider when choosing the right heating system for your home. The following provides information on some of the most popular options available today.

Natural gas furnaces are still one of the most common systems especially in older homes. New furnaces cost about \$4,700 to install. There might be a small rebate of \$500 on energy efficient models. Annual operating runs about \$1,800 a year.

Heat pumps provide not just heat but also cooling. Annual operating is less at about \$400. There are rebates of about \$2,800 because the systems are expensive to install at \$8,500.

Traditionalists may prefer wood stoves. Not as many are sold so the rebate is under a thousand at \$700. A quality stove costs about \$4,200. Operating is about \$1,300 assuming you can source some wood for free.

Finally, solar panels are expensive to install at \$15,000 for a small house. The rebates though is usually a third of that price. Annual operating is about \$200 mostly for maintenance.

Note: all figures are estimates and for demonstration purposes only.



Ref: Bow Valley College. (2020). Heating Systems: What's Best?. Calgary, Canada: Author.

HANDOUTS: House Front Measurement (1 page)
Skill Builders: Calculating Area, Rounding, Technical Drawings

IN THE WORKPLACE: Calculations of area are often used to determine amounts of material required to cover surface of various shapes, such as paint or siding on a house. Accurate calculations minimize waste and save time and money.

- Use the measurements and information given below to **calculate the total area** of the wooden slatted part of the house front – excluding the door and windows. Round your answer to the nearest whole number.

A: 9.7 m	B: 7.6 m	C: 8.8 m	D: 4.5 m
E: 2.3 m	F: 2.7 m	G: 1.2 m	H: 1.0 m

- All measurements are approximate.
- Assume all rectangular windows are the same size.
- The round window measurement is the diameter of the window.
- The measurement for the door includes the steps.
- Use 3.142 for π if you do not have your phone or scientific calculator.



This is the [Ruben M. Benjamin House](#) in Bloomington Illinois, listed on The United States National Register of Historic Places (Record Number: 376599).

Ref: Adapted by skillsyouneed.com. From: A. McMurray (Photographer). (March 16, 2007). Ruben M. Benjamin House [Photograph]. https://commons.wikimedia.org/wiki/File:Bloomington_IL_Benjamin_House2.JPG (CC By-SA 3).

HANDOUT: Invoice 1 (2 pages)

Skill Builders: Entry Forms, Tables & Lists

IN THE WORKPLACE: Accurately calculating information in complex forms such as invoices and work orders is a common task across trades. Errors in billings including hours worked and materials costs can result in significant losses to the company in time and hours worked

Use the **Crown Tools & Contracting Invoice** to complete the following tasks.

1. Enter the information below to complete the invoice for the following items and services.
 - a. Deluxe tool set (121 pieces) @ \$79 x 5 units
 - b. Featherweight Industrial ladder @ \$156
 - c. Heavy duty 6080N fire extinguisher @ \$99.99 x 3 units
 - d. Workshop wet-dry vac @ \$139
 - e. Site visit: labour 3.5 hours @ \$127

2. Calculate the subtotal, taxes, and final total and enter the information on the invoice. Use 5% GST for labour and 11% for items and materials.

3. Crown Tools & Contracting offers a 15% discount on items and materials (not labour) for returning customers. The calculation is made before taxes are added. Recalculate the invoice to apply the discount. What is the new total?



**CROWN TOOLS &
CONTRACTING**

We treat you like royalty!

INVOICE

TO:

Alicia Wu
LANDER CORP.
1234 Main Street
Anytown, AB, T1T 1T1
(403) 888-8888

Salesperson	Invoice #	Payment Terms	Due Date
R. Johnson	0019-23	Due on receipt	Oct 27, 2019

Qty	Description	Unit Price	Line Total
	Taxes:		
	Labour @ 5% =		
	Items and materials @ 11% =		
		Subtotal	
		Sales Tax	
		Total	

Thank you for your business!

Crowns Tools & Contracting, Warehouse CC. 23rd Street E, Anytown, AB

HANDOUT: Invoice 2 (2 pages)

Skill Builders: Conversion, Entry Forms, Tables & Lists

IN THE WORKPLACE: Accurately calculating information in complex forms such as invoices and work orders is a common task across trades. Errors in billings including hours worked and materials costs can result in significant losses to the company in time and hours worked.

Use the **ABC Pro Supplies Invoice** to complete the following tasks.

1. Enter the information below to complete the invoice for the following items and services. Convert any items shown in imperial to metric measurements before entering.
 - a. Apprentice tool set (11 pieces: Klein) @ \$314 x 5 units
 - b. 11 inch insulated rubber gloves @ \$66.50 x 3 units
 - c. Heavy duty 6080N fire extinguisher @ \$99.99 x 3 units
 - d. Pull-it 4-pack @ \$38.95
 - e. 5 lbs. carton of cast iron rods, $\frac{1}{4}$ in diameter and 24 in length @ \$37 x 2 units
 - f. 32 inch mechanical pick-up tool @ \$39.54
 2. Calculate the subtotal, taxes (at 11%) and final total and enter the information on the invoice.
 3. ABC Pro Supplies offers a 7% discount on items and materials for returning customers. The calculation is made before taxes are added. Recalculate the invoice to apply the discount. What is the new total?
-

HANDOUT: Map Reading: Estimation (3 pages)

Skill Builders: Key Words & Phrases, Rounding, Technical Drawings

IN THE WORKPLACE: Map reading is a key skill whether getting to and from a job or doing the work required by the job. Maps usually have a scale (in km and/or miles), a grid, and a key or legend containing symbols.

Refer to the **Map of Ontario** to complete the tasks below. Write the answers in the space provided or **highlight** them on the map.

1. Based on information provided in the map legend, what is the main difference between Lake Michigan and the other Great Lakes?

2. What geographical feature defines the southern part of the Ontario – Quebec border?

3. If the scale on the map is 4 cm long, how many centimeters represent 200 km?

4. Using the scale as a reference, complete the following table. Estimate the distances and assume driver drives an average of 80 km an hour. Round your answers up to the nearest 30 minutes.

Travel From	To	Km	Time
Ottawa	North Bay		
Toronto	Ottawa		
Sault Ste Marie	Pembroke		

5. There are 2 possible routes from North Bay to Thunder Bay: one goes north; the other south. Estimate the distance of, and the time it would take to travel, each route, driving an average of 80 km an hour. Check your answers using your phone or a maps app.

6. You are driving from Toronto to Kenora.

a) Estimate, using the scale, what you think the total distance is. _____

b) You want to drive approximately the same number of hours each day and will drive an average of 100 km an hour. Complete the following table to show where you would stop each night. Verify your calculations using your phone or GPS.

Days	Travel From	To	Km	Time
1	Toronto			
2				
3		Kenora		

Map of Ontario
(South of Moosonee)



© 2002. Her Majesty the Queen in Right of Canada, Natural Resources Canada.
Sa Majesté la Reine du chef du Canada, Ressources naturelles Canada.

Ref: Natural Resources Canada. (2002). Map of Ontario. [Map]. Ottawa, Canada: Queens Printer

HANDOUT: Measuring Temperature (2 pages)

Skill Builders: Conversion

IN THE WORKPLACE: Accurately taking and interpreting measurements are fundamental skills across the trades. Errors in interpreting and reporting measurements can result in significant losses to the company in product lost or equipment damaged. In the oil and gas industry, mud mixtures need to be maintained at constant temperatures between 15 and 20 degrees Celsius OR between 70 and 80 degrees Celsius.

Refer to the **Thermometers** on the next page to answer the following questions.

1. Compare measurements A and B. Which mixture is hotter?

2. What is the temperature in degrees Celsius of the mixture measured in C?

3. Calculate the temperature in degrees Fahrenheit of the mixture measured in E. Round your answer to the nearest whole degree.

4. Which is the coolest mixture?

5. The temperature measurements were taken, in the order presented, from the same site over the course of one day. Any sudden changes in temperature need to be reported. Which measurement(s) signal a sudden change?

6. Review all the temperature measurements taken. Describe the trend that occurred over the day.

7. To measure the temperature and other properties of the mud mixture safely workers need to wear appropriate PPE. The available heat-resistant gloves are recommended for use with temperatures over 110 degrees F. For which measurement(s) should heat resistant gloves be worn?

Thermometers



Thermometer A



Thermometer B



Thermometer C



Thermometer D



Thermometer E



Thermometer F



Thermometer G



Thermometer H

Ref: Bow Valley College. (2020). Thermometers. Calgary, Canada: Author.

HANDOUTS: Mixing Cement (2 pages)
Skill Builders: Conversion, Percentages

IN THE WORKPLACE: Errors in conversion can result in significant costs to a company in lost time and product. Accurately taking, interpreting and converting measurements between imperial and metric systems are fundamental skills across the trades.

Refer to the **Product Label** below to complete the tasks and answer the following questions. Show your calculations.

1. Convert the packet size to grams.
2. Convert 50-70 pounds to metric.
3. What is the recommended ratio of packets to kilos?
4. You have 160 kg of cement product. How many packets of QuickSET are needed?
5. The cement mixer has a 3.5 cubic foot capacity and will hold two 90 pounds bags of mix with water. To the nearest whole number, how many loads do you need to mix to use the 160 kg of cement product?

QuickSET

WATER REDUCING ADDITIVE

www.QuickSET.ca

Made in Canada.

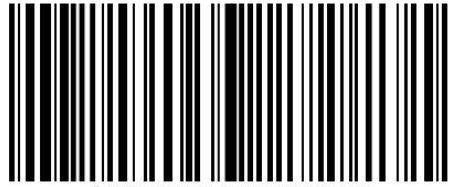

(00)123456789101112133

Directions: Place desired amount of water into mixing container. Add half cement product into mixing container and mix with mechanical mixer. Continue mixing while adding **QuickSET** powder to mixing container. Add remaining cement product into mixing container. **DO NOT** exceed 4 packets per 50 lb. to 70 lb. bag of cement product. Too much water in the mixture may cause aggregate segregation which can reduce strength. 1 packet contains 2.1 ounces.

Ref: Bow Valley College. (2020). QuickSET Product Label. Calgary, Canada: Author.

- Complete the following table for each of the tools shown in column 3 of Table 1 on the next page. Show the dBA for each tool and, using the data in the table you created, how many minutes of exposure is considered safe. Round down the tool dBA to ensure the exposure is safe. The first one is done for you.

TOOL	dBA	Minutes
Arc welder	90	240 minutes (4 hours) *rounded down to 88 dBA

Table 1

dBA	Example	Home & Yard Appliances	Workshop & Construction
0	healthy hearing threshold		
10	a pin dropping		
20	rustling leaves		
30	whisper		
40	babbling brook	computer	
50	light traffic	refrigerator	
60	conversational speech	air conditioner	
70	shower	dishwasher	
75	toilet flushing	vacuum cleaner	
80	alarm clock	garbage disposal	
85	passing diesel truck	snow blower	
90	squeeze toy	lawn mower	arc welder
95	inside subway cart	food processor	belt sander
100	motorcycle (riding)		handheld drill
105	sporting event		table saw
110	rock band		jackhammer
115	emergency vehicle siren		riveter
120	thunderclap		oxygen torch
125	balloon popping		
130	peak stadium crowd noise		
135	air raid siren		
140	jet engine at takeoff		

Ref: Bow Valley College. (2020). Noise Levels. [Table]. Calgary, Canada: Author.

HANDOUT: On the Job Calculations (2 pages)

Skill Builders: Conversion, Rounding, Percentages, Decimals & Fractions

IN THE WORKPLACE: Errors in conversion can result in significant costs to a company in lost time and product. Accurately taking, interpreting and converting measurements between imperial and metric systems are fundamental skills across the trades. Welders are one example of a trade that frequently works across both systems.

Calculate the answers to the following questions. Round all answers to 2 decimal places.

1. Substrate needs to be 30.5×38 centimetres. How many square inches is that?
2. How many square centimetres is a 4-inch^2 piece of glass?
3. When making a cut, the cutter should be 0.06 inches from the edge of the glass. How many millimetres is that?
4. Calculate the area in square of centimetres of a piece of glass that measures 6 feet \times 3 inches.

5. A project requires 3.5 metres of electrode wire. Calculate the length in millimetres, centimetres and inches.
6. An electrode wire stickout is $\frac{3}{8}$ inch. Calculate the length in millimetres and centimetres.
7. Convert the following quantities to the metric measurements provided.

a) 2 lbs. of flux	kg
b) 4 quarts (US) of solution	L
c) $\frac{3}{4}$ in. pipe	cm
d) 100 lbs. of fire brick	kg
e) 18 in. welding rod	cm

4. Steer manure needs to be ordered to fill the garden from the ground level to the top of the timbers. Manure is ordered in cubic metres. Assume the timbers are 4 x 4 inches and the manure needs to be level with the top of the timbers. How many cubic metres need to be ordered? *Round to the nearest hundredth. Recall the concept for area, volume and the conversion ratio provided (1 m = 39.37 in.).*

Recall: Area of a triangle = B (base) x H (height) ÷ 2

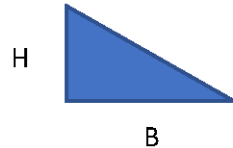

Recall: Volume of triangular prism = B (base) x L (length)

- where B = triangular area forming the base of a triangular prism;
- where L= the overall length (or height (H) or depth (D)) of the third dimension in the triangular prism.

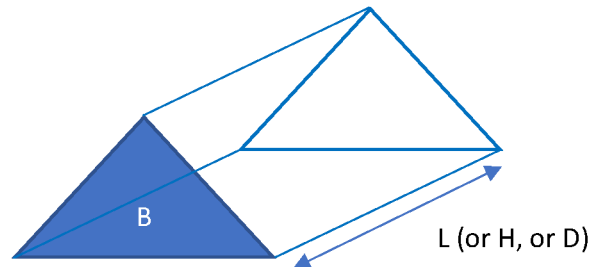

5. Assume the patio is a rectangle and the shortest side of the garden is 1/6 of the width of the finished patio. The longest side of the patio is 1.5 times the length of the shortest side. Using the graph paper on the next page, draw and label the patio including the new garden. Include information on the scale you use.

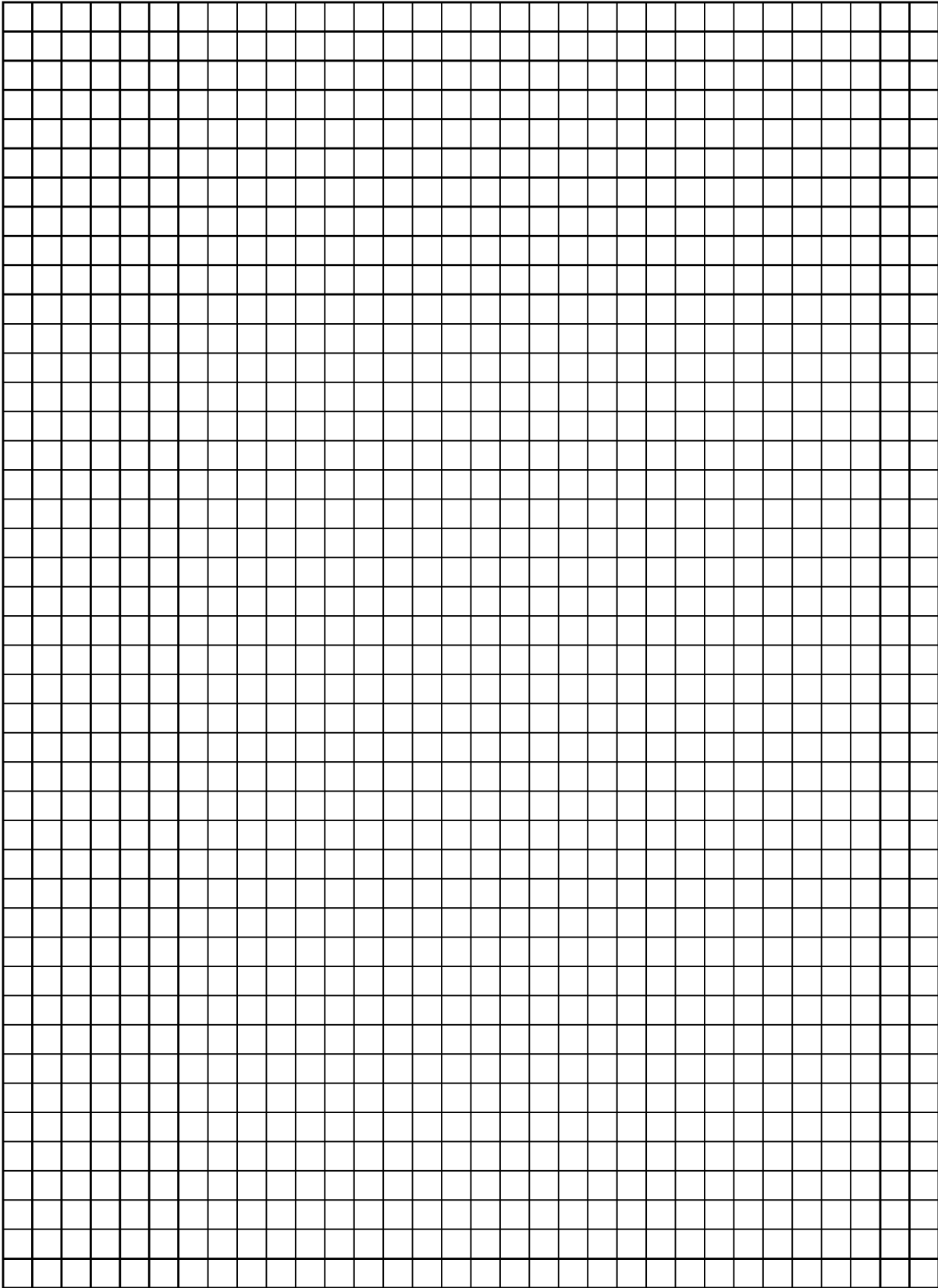

HANDOUTS: Pay Statements (3 pages)

Skill Builders: Key Words & Phrases, Entry Forms, Percentages, Decimals & Fractions

IN THE WORKPLACE: As a pre/apprentice and as a journeyperson, tracking your income is important. Understanding required deductions and the difference between gross and net earnings provides an accurate picture of your finances.

1. Refer to **Pay Statements 1** and **2** to complete the following table.

	Pay Statement 1	Pay Statement 2
Worker name		
Cheque number		
Pay period end date		
Pay date		
Total hours worked		
Gross pay		
Net pay		
Year to date gross		
Current EI deduction		
Year to date CPP deduction		

2. What do CPP, EI and YTD stand for?

3. What type of employee ID does each company use?

4. Calculate the CPP and EI rates on Pay Statement 1.

5. If the rate of deduction for CPP goes up 1%, calculate the new deduction amounts for each employee for this pay period.

6. Calculate the total percentage of the deductions for this pay period for each employee.

Pay Statement 1

Thompson Construction, 123 Home Street, WINNIPEG MB CANADA, R2W 2Y8						EARNINGS STATEMENT	
John Smith							
EMPLOYEE ID		PERIOD ENDING		PAY DATE		CHECK NUMBER	
123456		2013/11/25		2013/11/20		321654	
INCOME	RATE	HOURS	CURRENT TOTAL	DEDUCTIONS	CURRENT TOTAL	YEAR TO DATE	
REGULAR	20	80	1,600.00	CPP	65.03	1,495.69	
OVERTIME	25	5	125.00	EI	28.62	658.26	
				INCOME TAX	305.90	7,035.70	
				UNION DUES	10.84	249.32	
				LIFE INSURANCE	4.94	113.62	
				LONG TERM DISABILITY	7.01	161.23	
				CANADA SAVINGS BOND	8.00	184.00	
YTD GROSS	YTD DEDUCTIONS		YTD NET PAY	CURRENT TOTAL	DEDUCTIONS	NET PAY	
39,675.00	9,897.82		29,777.18	1,725.00	430.34	1,294.66	

Pay Statement 2

Joseph Mayer		Employee #:	0032344589	Employer #:	11-36	Pay from:	2018/11/12	To:	2018/11/25	Date:	2018/12/03
STATEMENT OF EARNINGS				DEDUCTIONS							
EARNINGS	HOURS	RATE	CURRENT AMOUNT	WITHOLDINGS	CURRENT AMOUNT	YEAR-TO-DATE					
001 BASIC PAY	75.00	16.00/hr	1,200.00	EI	22.56	564.00					
				CPP/QPP	52.74	1,318.50					
				INCOME TAX	156.61	3,915.25					
SUMMARY		GROSS PAY	DEDUCTIONS	NET PAY	CHEQUE #						
CURRENT		1,200.00	231.91	968.09	0044853						
YEAR-TO-DATE		30,000.00	5,797.75	24,202.25							

Ref. Pay Statement 1: Adapted from Canada Online Pay Stub Generator. (2018). Sample Pay Stub (Earnings Statement). Canada: www.canadapaystubs.com,

Ref. Pay Statement 2: Canada Revenue Agency. (2019). Sample-Statement of earnings (pay stub). Ottawa, Canada: <https://www.canada.ca/en/revenue-agency/services/tax/individuals/educational-programs/student-worksheets/statement-earnings.html>

HANDOUTS: Product Installation (2 pages)

Skill Builders: Conversion, Technical Drawings, Rounding & Percentages, Decimals & Fractions

IN THE WORKPLACE: Contractors, estimators, builders and tradespersons all rely on technical drawings for the information they need to safely and accurately build, repair or install a product such as a dishwasher as shown below.

Use the **Basic and Cutout Dimensions** technical drawings to complete the following tasks.

- The technical drawings include both metric and imperial measurements. Calculate the correct conversion to centimetres for the five measurements that are circled and lettered, on the drawing. Round to the nearest tenth. (1 inch = 2.54 cm)

A. _____

B. _____

C. _____

D. _____

- If the dishwasher requires a half inch clearance on all 3 sides, and a half inch at the top, what are the dimensions of the largest dishwasher that will fit in the opening? Include width, depth, and height. Show your answers in imperial and metric.

- Calculate the cubic volume of the opening in imperial. Use the Cutout Dimensions technical drawing.

- Trim pieces are provided with the unit to fit the opening shown in the drawing. Without side trims, the unit width and depth is 59.7 cm. Without top trim, the unit height is 85.7 cm. Calculate the difference in volume between the unit with trim and without trim. Show your answer in imperial units. Round volume to the nearest whole number. (1 in.³ = 16.39 cm³).

CUTOUT DIMENSIONS

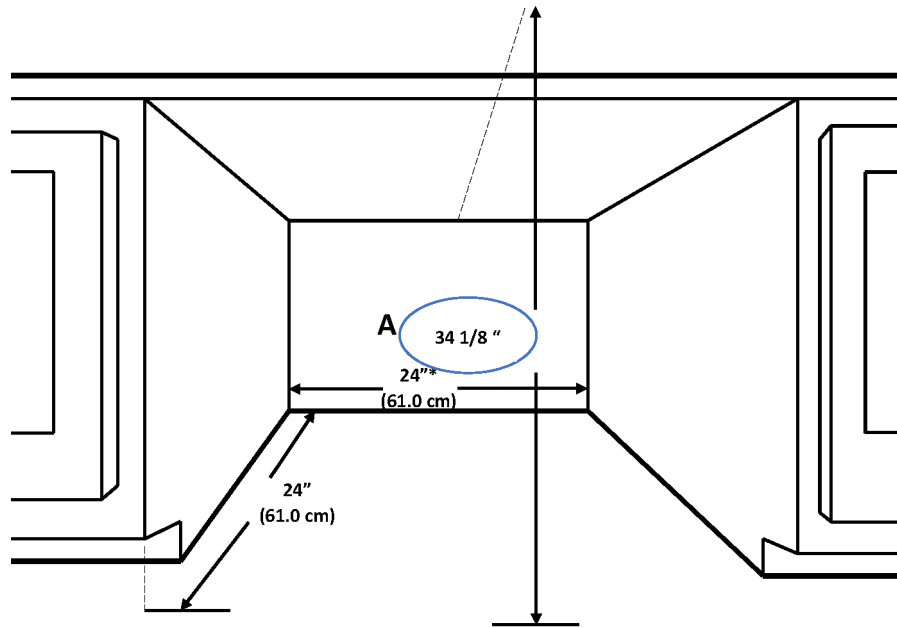

BASIC DIMENSIONS

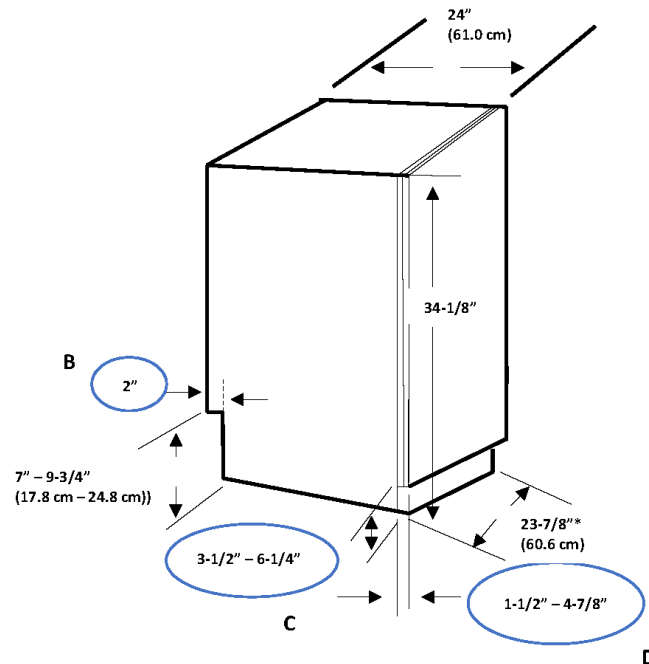

Ref: Bow Valley College. (2020). Basic Dimensions. [image]. Calgary, Canada: Author.

HANDOUT: Rough Openings: Calculation (3 pages)
Skill Builder: Tables & Lists, Technical Drawings

IN THE WORKPLACE: To ensure that doors and windows fit tight enough to prevent water and air leaks, rough openings must be made larger than the item to be installed. The added space allows for variations such as headers or floors that are out of level and openings that are slightly out of square.

Refer to the **Rough Openings** documents to complete the tasks and locate answers to the questions. Write the answers in the space provided or **highlight** the information on the blueprint.

1. Locate the following:

a) Frame width for a 5' door:

b) Opening height for the tallest 2'10" outswing door

c) Minimum rough opening width for the smallest double door available

d) Maximum opening height for 5' 8" door

2. Calculate the following:

a) 80" in feet

b) 63 ¼" in feet

c) 84 ½" in feet

- The rough opening was made for a 2'8" single door and should have been for a 4'8" double. Using the minimum rough opening dimensions for both, how much larger does the opening need to be?

- Calculate the difference between the largest opening height for a 2'6" inswing door and a 5'4" double outswing door.

- Label the illustration showing the rough opening measurement for the smallest double door shown in the chart.
- Label the illustration showing the shortest rough opening height measurement for a 6' 0" double outswing door.
- Refer to your textbook, or search online, to locate the rough opening width and height for a common window and door size. Label the illustration with those dimensions.

Rough Openings

Door Description	Opening Width		Opening Height	
	Actual Frame Width Size	Stud to Stud Rough Opening Minimum	6' 8"	7' 0"
2' 0" Single	25 ½"	26"	Inswing 82" Outswing 81 ¼"	Inswing 86" Outswing 85 ¼"
2' 4" Single	29 ½"	30"		
2' 6" Single	31 ½"	32"		
2' 8" Single	33 ½"	34"		
2' 10" Single	35 ½"	36"		
3' 0" Single	37 ½"	38"		
4' 8" Double	58"	58 ½"	Inswing 82" Outswing 81 ¼"	Inswing 86" Outswing 85 ¼"
5' 0" Double	62"	62 ½"		
5' 4" Double	66"	66 ½"		
5' 8" Double	70"	70 ½"		
6' 0" Double	74"	74 ½"		

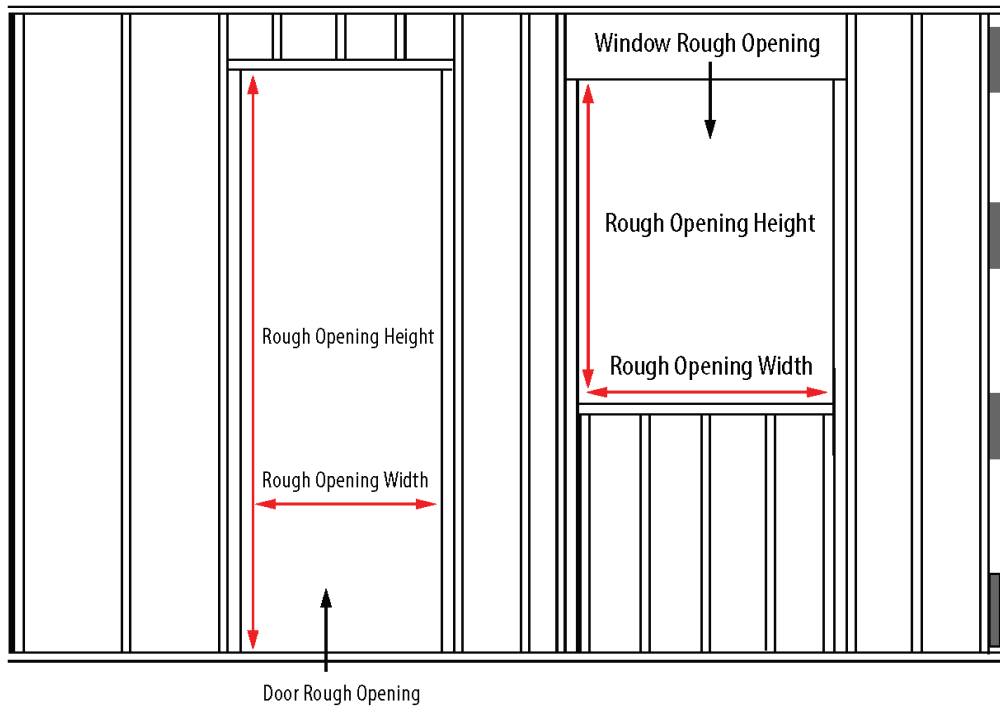

Ref: Bow Valley College. (2020). Rough Openings. [table]. Calgary, Canada: Author.

HANDOUT: Rough Openings: Conversion (3 pages)

Skill Builders: Conversion, Rounding, Tables & Lists

IN THE WORKPLACE: To ensure that doors and windows fit tight enough to prevent water and air leaks, rough openings must be made larger than the item to be installed. The added space allows for variations such as headers or floors that are out of level and openings that are slightly out of square.

1. Convert the following from inches to mm. Include the unit in your answer. (1 in. = 25.4 mm)

a) $27\frac{3}{4}$ "

b) 84"

c) $71\frac{1}{4}$ "

2. Convert the following from mm to inches. Calculate to the closest $\frac{1}{8}$ ". Include the unit in your answer. (1 in. = 25.4 mm)

a) 2032 mm

b) 915 mm

c) 1000 mm

3. Complete the following table of popular door sizes. Include the unit in your answers. Calculate all metric measurements to the nearest whole number.

Metric mm	Imperial feet & inches	Imperial inches
1830 mm x 610 mm	6' 0" x 2' 0"	
	6' 6" x 1' 6"	78" x 18"
1981 mm x 762 mm		78" x 30"
	6' 8-1/4" x 2' -1/8"	80-1/4" x 24-1/8"
2040 mm x 721 mm	6' 8-5/16" x 2' 4-3/8"	

4. Recreate the Opening Height sub-headings and the first 2 lines of the **Rough Openings** table using metric instead of imperial measurements. Calculate to the nearest whole number. Include the unit in your answers.

Rough Openings

Door Description	Opening Width		Opening Height	
	Actual Frame Width Size	Stud to Stud Rough Opening Minimum		
			Inswing	Inswing
			Outswing	Outswing

Rough Openings

Door Description	Opening Width		Opening Height	
	Actual Frame Width Size	Stud to Stud Rough Opening Minimum	6' 8"	7' 0"
2' 0" Single	25 ½ "	26 "	Inswing 82" Outswing 81 ¼"	Inswing 86" Outswing 85 ¼"
2' 4" Single	29 ½ "	30"		
2' 6" Single	31 ½ "	32 "		
2' 8" Single	33 ½ "	34 "		
2' 10" Single	35 ½ "	36 "		
3' 0" Single	37 ½ "	38 "		
4' 8" Double	58"	58 ½ "	Inswing 82" Outswing 81 ¼"	Inswing 86" Outswing 85 ¼"
5' 0" Double	62 "	62 ½ "		
5' 4" Double	66 "	66 ½ "		
5' 8" Double	70"	70 ½ "		
6' 0" Double	74"	74 ½ "		

Ref: Bow Valley College. (2020). Rough Openings. [table]. Calgary, Canada: Author.

HANDOUTS: Tiny House (2 pages)
Skill Builders: Calculating Area, Technical Drawings

IN THE WORKPLACE: Contractors, estimators, builders and tradespersons all rely on technical drawings for the information they need to build safely and accurately.

Use the **Technical Drawing** on the next page to locate the answers to the following questions.

1. Is the structure intended to be fixed in place or movable? How do you know?

2. How many stories is the structure?

3. What is the exterior perimeter of the structure?

4. What is the total square footage of the sleeping area?

5. What are the dimensions of the staircase?

6. How many exits are there? Where are they?

7. What is the total square footage of the loft space?

8. What is the square footage of the kitchen?

9. What are the dimensions of the bathroom?

10. If a city bylaw permits tiny houses that occupy no more than $\frac{1}{2}$ of the existing backyard, how large must the yard be to accommodate this structure?

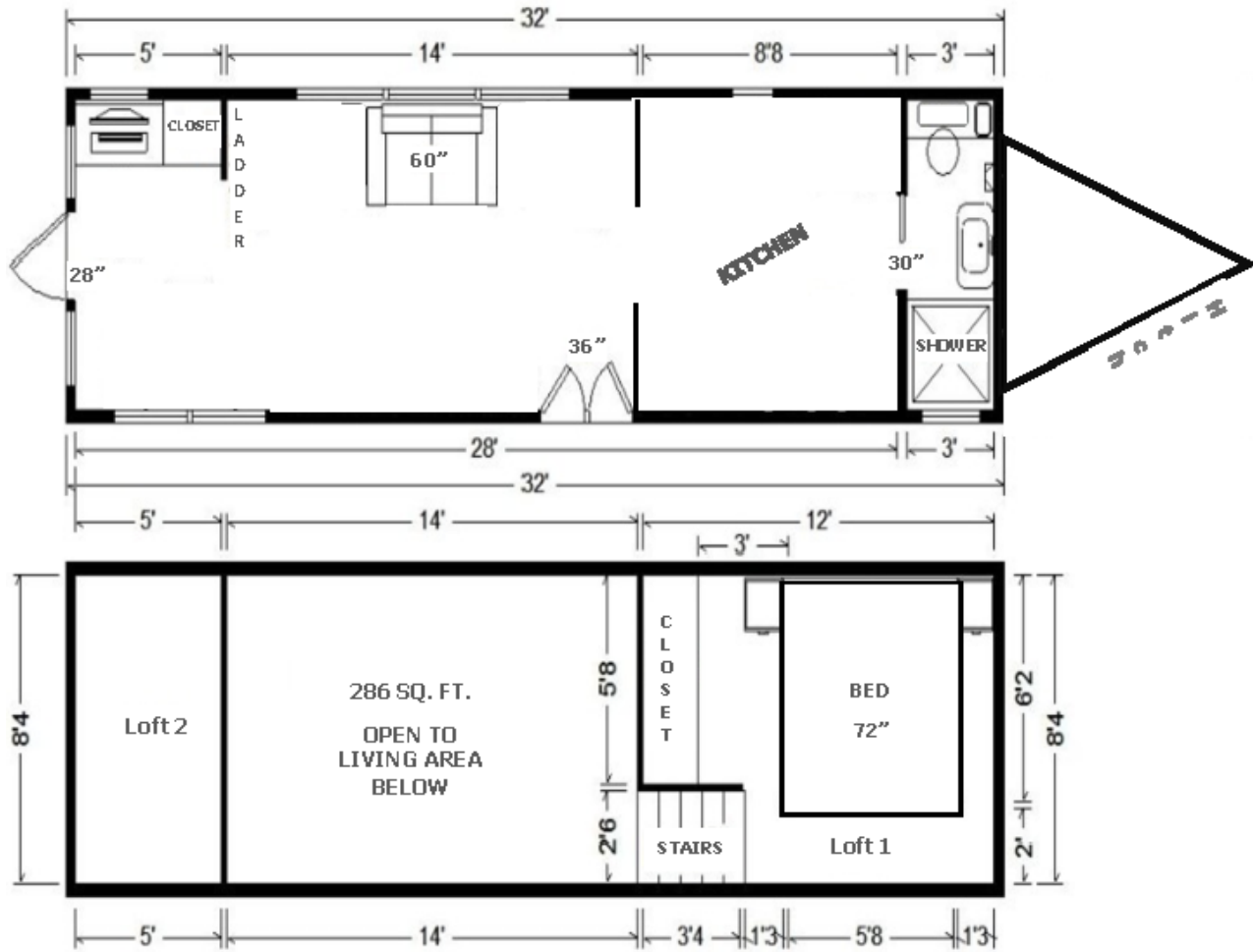

Ref: Bow Valley College. (2020). Tiny house. [Floor Plan]. Calgary, Canada: Author

HANDOUT: Volume of Cylinders and Cones (2 pages)

Skill Builder: Volume, Rounding

IN THE WORKPLACE: Plumbers and other tradespersons frequently work with materials that are round or curved to allow for the easy flow or storage of fluids. Calculating volume is done in both metric and imperial systems of measurement.

Calculate answers to the following questions. Include the units in your answers. Show your calculations.

1. A cylindrical septic tank is 1.2 m in diameter and 1.8 m high. How many litres will it hold?
Round to the nearest whole number. ($1 \text{ m}^3 = 1000 \text{ L}$)

2. A rainwater downpipe is 30" high and 4" wide. Calculate the volume of the pipe, in litres.
Round to the nearest hundredth. ($1 \text{ L} = 61.023 \text{ in.}^3$)

3. Residential sewer pipe, connected to a toilet, must have a diameter that is a minimum of 3".
Using that standard, if the pipe is 20' long, calculate the volume of the pipe in litres.
Round to the nearest tenth. ($1 \text{ L} = 61.023 \text{ in.}^3$).

4. A storage tank is 13' in diameter and 3m high. How many gallons will it hold? There are
7.481 cubic feet in a US liquid gallon. Round to the nearest hundredth.
($1 \text{ gal. (US)} = 7.48 \text{ ft}^3$) and ($1 \text{ m} = 3.28 \text{ ft.}$)

5. A storm water pipe has an exterior dimension of 8" and the interior dimension is 1" smaller. Calculate the volume, of the pipe, in litres, per 50'. Round to the nearest hundredth. (1 L = 61.023 in.³)

6. Once it is welded, the bottom cone for a grain hopper will have a height of 2.04 metres and the radius will 1.57 metres. How much grain will the cone hold? Round to the nearest hundredth.

7. By looking at the amount of fill dropped off at a construction site, the foreperson estimates that it is not going to be enough for the area that needs to be filled. The fill is piled in a cone shape on the edge of the site. The amount ordered was 100 m³. The pile of fill is 7.5 m high with a diameter of 7 m. Was enough fill delivered? Show your calculations. Round to the nearest tenth.

8. Engine cleaner needs to be diluted at 180 mL of liquid concentrate in 4 litres of water. Is the bucket below large enough to hold the mixture? Round to the nearest hundredth. (1 mL = 1000 m³) and (1 L = 1000 mL)



HANDOUTS: Work Schedules (3 pages)
Skill Builders: Key Words & Phrases, Tables & Lists

IN THE WORKPLACE: As a pre/apprentice and as a journeyman, the ability to accurately follow a schedule is important: especially when working multiple projects. Arriving on time – and at the right location – either first thing in the morning or following any breaks is essential.

Refer to the **Crews and Schedule** form to locate the answers to the following questions.

1. How many days a week does the company operate?

2. Which crew has the fewest working days this period?

3. Crew B needs to add a day on Monday the 21. Which crew is available to assist?

4. Which projects are scheduled for the shortest period of time?

5. Kim is unable to work on the final day of the 42nd Avenue project. What workers could be available to pick up the shift?

6. Which crew will be working at Paper Street site on the June 25?

7. Which crew works the fewest number of job sites this period?

8. On which day will work at 659 Treesdale Crt be completed?

9. Which crew does not work Saturdays?

10. Each shift is 8.5 hours. How many hours will Hester work during this pay period?

Crews & Schedule

Pay period: June 13 – June 26



	Week 1						Week 2					
	M 14	T 15	W 16	Th 17	F 18	S 19	M 21	T 22	W 23	Th 24	F 25	S 26
217 Brentley Dr		A	A									
18 Roman Cres				A	A		A	A				
10471 Main St S									C			
985 4 th Ave									C	C	C	
659 Treesdale Crt		B	B	B	B	B						
287 Crawford Ave									A	A	A	
8215 Teal Trail	A											
36 Paper St		C	C	C	C	C		B	B	B	B	B

Crew A
Roger (Lead)
Marshall
Greg
Topher

Crew B
Lesley (Lead)
Frank
Ralf
Jean

Crew C
Joe (Lead)
Toni
Kim
Steve
Hester

Ref: Bow Valley College. (2020). Work Schedule. [image]. Calgary, Canada: Author



Numeracy Answer Keys



ANSWER KEY: Door Order Sheet
Skill Builders: Entry Forms, Technical Drawings

1. What 2 purposes is the form used for? **Recording a quote or completing an order.**
2. What measurement system does the form use? **Imperial (inches).**
3. How many gauges of metal door are always available? What are they? **18 gauge and 16 gauge are always available. (14 gauge may not be available.)**
4. What do the abbreviations PO and QUAN mean? **PO = purchase order, QUAN = quantity.**
5. In addition to hinges, latch, edge seam and prime, what 3 features of door construction must be selected to complete an order? **Metal gauge, metal material and core.**
6. Measure all of the doorways in the room you are in. Enter that information in the form in the columns: quan, net width, net length and thickness. **Figures will vary.**
7. Draw and label a door using the dimensions from one of the doors you just measured. Include height, width, and depth measurements. Show hinge locations, door knob and any windows in the door. Use the graph paper provided and the scale 1 square = 3 inches. **Drawings will vary.**

ANSWER KEY: Heating Systems
Skill Builders: Key Words & Phrases, Charts & Graphs, Tables & Lists

1. What is the main focus of the article? **The cost of different heating systems**
2. What systems are being compared? **Gas furnaces, heat pumps, wood stoves and solar panels**
3. What specific features are being compared? **The costs of installation and annual operating, and any available rebates**
4. Calculate for each system the total cost after each of the following.
Calculation = install- rebate + [annual operating cost x # years]
 - a.

	1 year
Heat Pump	\$6, 100
Gas Furnace	\$6, 000
Wood Stove	\$4, 800
Solar Panels	\$10, 200

b.

	10 years
Heat Pump	\$9, 700
Gas Furnace	\$22, 200
Wood Stove	\$16, 500
Solar Panels	\$12, 000

c.

	20 years
Heat Pump	\$13, 700
Gas Furnace	\$40, 200
Wood Stove	\$29, 500
Solar Panels	\$14, 000

5. Organize the information in the article as a table. **Layout may vary.**

	Installation	Rebate	Annual Operating
Heat Pump	\$8,500	\$2,800	\$4,00
Gas Furnace	\$4,700	\$500	\$1,800
Wood Stove	\$4,200	\$700	\$1,300
Solar Panels	\$15,00	\$5,000	\$200

6. Organize the information in the article as a bar chart. **Layout may vary.**

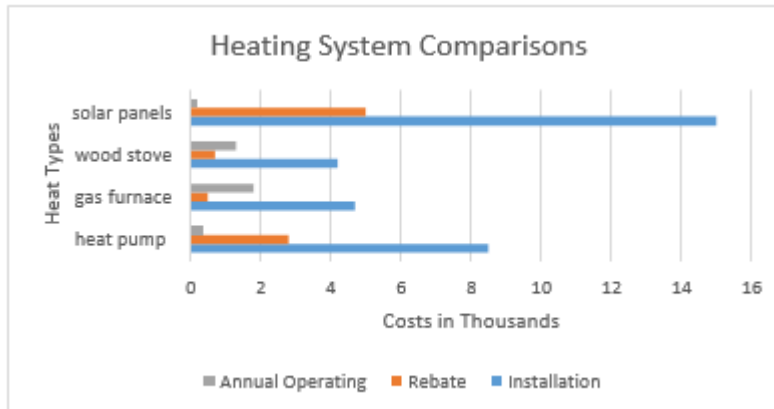

7. Which layout do you think is easiest to understand? Why? **Answers will vary.**

ANSWER KEY: House Front Measurement
Skill Builders: Calculating Area, Rounding, Technical Drawings

1. The area of the wooden slatted front of the house is 48.7845 m^2 . Rounding up, the answer is **49 m^2** .

Suggested steps for calculating the answer:

- A. First, work out the area of the main shape of the house – that is the rectangle and triangle that make up the shape.
- The main rectangle ($B \times C$) or $7.6 \times 8.8 = 66.88 \text{ m}^2$.
 - The height of the triangle is ($A - B$) or $9.7 - 7.6 = 2.1 \text{ m}$.
 - The area of the triangle is therefore $[(2.1 \times C) \div 2]$ or $[(2.1 \times 8.8 = 18.48) \div 2]$.
 $18.48 \div 2 = 9.24 \text{ m}^2$.
 - The combined full area of the front of the house is the sum of the areas of the rectangle and triangle: $66.88 + 9.24 = 76.12 \text{ m}^2$.
- B. Next, work out the areas of the windows and doors, so they can be subtracted from the full area.
- The area of the door and steps is ($D \times E$) or $4.5 \times 2.3 = 10.35 \text{ m}^2$.
 - The area of one rectangular window is ($G \times F$) or $1.2 \times 2.7 = 3.24 \text{ m}^2$.
 - There are five rectangular windows. Multiply the area of one window by 5.
 $3.24 \times 5 = 16.2 \text{ m}^2$.
 - The round window has a diameter of 1m its radius is therefore 0.5 m.
 - Using πr^2 work out the area of the round window. Use 3.142 for π .
 $3.142 \times 0.5 \times 0.5 = 0.7855 \text{ m}^2$.
- C. Next add up the areas of the door and windows.
(door area) $10.35 +$ (rectangle windows area) $16.2 +$ (round window area) 0.7855
 $= 27.3355 \text{ m}^2$
- D. Finally, subtract the total area for the windows and doors from the full area.
 $76.12 - 27.3355 = 48.7845 \text{ m}^2$
- E. Round the full area to the nearest whole number.
 $48.7845 \text{ m}^2 = 49 \text{ m}^2$

ANSWER KEY: Invoice 1
Skill Builders: Entry Forms, Tables & Lists

Questions 1 and 2. See the entries in the invoice below.



**CROWN TOOLS &
CONTRACTING**

We treat you like royalty!

INVOICE

TO: Alicia Wu
LANDER CORP.
1234 Main Street
Anytown, AB, T1T 1T1
(403) 888-8888

Salesperson	Invoice #	Payment Terms	Due Date
R. Johnson	0019-23	Due on receipt	Oct 27, 2019

Qty	Description	Unit Price	Line Total
5	Deluxe tool set (121 pieces)	79.00	395.00
1	Featherweight industrial ladder	156.00	156.00
3	Heavy duty 6080N fire extinguisher	99.99	299.97
1	Workshop wet-dry vac	139.00	139.00
3.5	Site Visit	127.00	444.50
Taxes:			
	Labour @ 5% =	22.23	22.23
	Items and materials @ 11% =	108.90	108.90
Subtotal			1,434.47
Sales Tax			131.13
Total			\$1,565.60

Thank you for your business!

Crowns Tools & Contracting, Warehouse CC, 23rd Street E, Anytown, AB

3. Crown Tools & Contracting offers a 15% discount on items and materials (not labour) for returning customers. The calculation is made before taxes are added. Recalculate the invoice to apply the discount. What is the new total? **\$1,400.76**.

One way to calculate the answer:

- a. Calculate the total of the items and materials (not labour): 989.97
- b. Multiply by 0.85: 841.47
- c. Calculate the tax on the new amount: $841.47 \times .11 = 92.56$
- d. Add the items and materials and tax costs: $841.47 + 92.56 = 934.03$
- e. Add the labour and tax costs: $934.03 + 444.50 + 22.23 = 1,400.76$
- f. New total: = \$ 1,400.76

ANSWER KEY: Invoice 2
Skill Builders: Conversion, Entry Forms, Tables & Lists

Questions 1 and 2. See the entries in the invoice below.



ABC Pro Supplies

INVOICE

Qty	Description	Unit Price	Line Total
5	Apprentice tool set (11 pieces; Klein)	314.00	1570.00
3	27.94 cm Rubber gloves	66.50	199.50
3	Heavy duty 6080N fire extinguisher	99.99	299.97
1	Pull-it 4-pack	38.95	38.95
2	2.27 kg carton of cast iron rods, 6.35 mm (0.635 cm) diameter and 609.6 mm (60.96 cm) in length	37.00	74.00
1	81.28 cm mechanical pick-up tool	39.54	39.54
		Subtotal	\$2221.96
		Sales Tax	\$244.42
		Total	\$2466.38

3. ABC Pro Supplies offers a 7% discount on items and materials for returning customers. The calculation is made before taxes are added. Recalculate the invoice to apply the discount. What is the new total?

New subtotal: $\$2,221.96 \times 0.93 = \$2,066.42$

New taxes: $\$2,066.42 \times 0.11 = \227.31

New total: $\$2,066.42 + \$227.31 = \$2,293.73$

ANSWER KEY: Map Reading: Estimation
Skill Builders: Key Words & Phrases, Rounding, Technical Drawings

- Based on information provided in the map legend, what is the main difference between Lake Michigan and the other Great Lakes?
All of Lake Michigan is in the United States. The international border runs through all the other lakes.
- What geographical feature defines the southern part of the Ontario – Quebec border?
The Ottawa River.
- If the scale on the map is 4 cm long, how many centimetres represent 200 km?
200 km = 2 cm.
- Using the scale as a reference, complete the following table. Estimate the distances and assume driver drives an average of 80 km an hour. Round your answers up to the nearest 30 minutes.
Estimates may vary, but should be close to those shown below. Note: time answers should be rounded up to the hour or half hour.

Travel From	To	Km	Time
Ottawa	North Bay	360 km	4.5 hours
Toronto	Ottawa	450 km	6 hours
Sault Ste Marie	Pembroke	650 km	8.5 hours

- There are 2 possible routes from North Bay to Thunder Bay: one goes north; the other south. Estimate the distance of, and the time it would take to travel, each route, driving an average of 80 km an hour. **Estimates may vary.**
Northern route: 1,110 km at 80 km/h: 13 hours, 53 mins.
Southern route: 1,140 km at 80 km/h: 14 hours, 15 mins.
- You are driving from Toronto to Kenora.
 - Estimate, using the scale, what you think the total distance is.
Approximately 1900 km. Estimate should follow available driving route options and should not be estimated as a straight-line route from point to point.
 - You want to drive approximately the same number of hours each day and will drive an average of 100 km an hour. Complete the following table to show where you would stop each night.
Answers are approximations.

Days	Travel From	To	Km	Time
1	Toronto	Elliot Lake	633	6:20
2	Elliot Lake	Marathon	633	6:20
3	Marathon	Kenora	633	6:20

ANSWER KEY: Measuring Temperature
Skill Builders: Conversion

1. Compare measurements A and B. Which mixture is hotter? **B**
2. What is the temperature in degrees Celsius of the mixture measured in C? **20° C**
3. Calculate the temperature in degrees Fahrenheit of the mixture measured in E. Round your answer to the nearest whole degree. **162° F** ($161.6^{\circ} \text{F} = 72^{\circ} \text{C}$)
4. Which is the coolest mixture? **A**
5. The temperature measurements were taken, in the order presented, from the same site over the course of one day. Any sudden changes in temperature need to be reported. Which measurement(s) signal a sudden change? **C to D**
6. Review all the temperature measurements taken. Describe the trend that occurred over the day. **Answers may vary. Suggested answer: Temperatures were constant for the first 3 readings. At reading 4 they jumped and slowly increased for the rest of the day.**
7. To safely measure the temperature and other properties of the mixture workers need to wear appropriate PPE. The available heat-resistant gloves are recommended for use with temperatures over 110 degrees F. For which measurement(s) should heat resistant gloves be worn? **(110° F = 43.3° C) Therefore the gloves should be worn for measurements D through H.**

ANSWER KEY: Mixing Cement
Skill Builders: Conversion, Percentages

1. Convert the packet size to grams.

$$2.1 \times 28.35 = 59.54 \text{ g}$$

2. Convert 50-70 pounds to metric.

Conversion factor is $1 \text{ kg} = 2.2 \text{ lb.}$

$$50 \text{ lb.} = 22.73 \text{ kg}$$

$$70 \text{ lb.} = 31.82 \text{ kg}$$

$$22.73 - 31.82 \text{ kg}$$

3. What is the recommended ratio of packets to kilos?

4 per 22.73 kg – 31.82 kg bag

OR

1 per 5.68 kg – 7.96 kg bag

4. You have 160 kg of cement product. How many packets of QuickSET are needed?

20 – 28.

Since you cannot exceed 4 packets of QuickSET per 50 lb.-70 lb. (22.73 kg-31.82 kg) bag of cement product, you must round down to the nearest whole number (i.e., you cannot add more packets of QuickSET to the mixture than specified).

5. The cement mixer has a 3.5 cubic foot capacity and will hold two 90 pounds bags of mix with water. To the nearest whole number, how many loads do you need to mix to use the 160 kg of cement product?

2 loads

ANSWER KEY: Noise Levels

Skill Builders: Charts & Graphs, Rounding, Tables & Lists

1. If the information in Table 1 was displayed as a chart, what would the title, and the labels of the x and y axes be? **Suggested answers. Title: noise levels. X axis (horizontal): noise sources. Y axis (vertical): dBA levels**
2. Create a table to represent the following text. Give the table a title that helps describe the information in the table. Label the columns. Include all data points between 85 and 115 dBA. Round times up to nearest 0.5 of a minute.

Extreme noise can have serious negative effects on an individual's hearing. At 85 dBA the maximum recommended exposure is 8 hours. At 88 it is reduced to 4 hours. According to the generally-accepted "dBA exchange rate", for every 3 dBA over 85, the permissible exposure is cut in half.

Sample Answer.**Title: Noise Levels by Maximum Recommended Exposure Time**

Noise Level (dBA)	Maximum Recommended Exposure Time
85	8 hours
88	4 hours
91	2 hours
94	1 hour
97	30 minutes
100	15 minutes
103	7.5 minutes
106	4 minutes (3.75 minutes)
109	2 minutes (1.875 minutes)
112	1 minute (0.9375 minutes)
115	0.5 minutes (0.46845 minutes)

3. Complete the following table for each of the tools shown in column 3 of Table 1 on the next page. Show the dBA for each tool and, using the data in the table you created, how many minutes of exposure is considered safe. Round down the tool dBA to ensure the exposure is safe. The first one is done for you.

TOOL	dBA	Minutes
Arc welder	90	240 minutes (4 hours) *rounded down to 88 dBA
Belt sander	95	60 minutes (1 hour)
Handheld drill	100	15 minutes
Table saw	105	7.5 minutes
Jackhammer	110	2 minutes
Riveter	115	0.5 minutes
Oxygen torch	120	No acceptable exposure

ANSWER KEY: On the Job Calculations**Skill Builders: Conversion, Rounding, Percentages, Decimals & Fractions**

1. Substrate needs to be 30.5 x 38 centimetres. How many square inches is that?

Step 1: Convert metric to imperial for 30.5 cm

(1 in. = 2.54 cm)

$$\frac{? \text{ in.}}{30.5 \text{ cm}} = \frac{1 \text{ in.}}{2.54 \text{ cm}} \quad \gg \quad ? \text{ in.} = \frac{30.5 \text{ in.}}{2.54} \quad \gg \quad ? \text{ in.} = 12.01 \text{ in.}$$

$$30.5 \text{ cm} = 12.01 \text{ in.}$$

Step 2: Convert metric to imperial for 38 cm

$$\frac{? \text{ in.}}{38 \text{ cm}} = \frac{1 \text{ in.}}{2.54 \text{ cm}} \quad \gg \quad ? \text{ in.} = \frac{38 \text{ in.}}{2.54} \quad \gg \quad ? \text{ in.} = 14.96 \text{ in.}$$

$$38 \text{ cm} = 14.96 \text{ in.}$$

Step 3: Calculate square inches

$$12.01 \text{ in.} \times 14.96 \text{ in.} = 179.67 \text{ in.}^2$$

2. How many square centimetres are in a 4-in² piece of glass?

Step 1: Convert imperial to metric

(1 in.² = 6.45 cm²)

$$\frac{? \text{ cm}^2}{4 \text{ in.}^2} = \frac{6.45 \text{ cm}^2}{1 \text{ in.}^2} \quad \gg \quad ? \text{ cm}^2 = \frac{6.45 \text{ cm}^2 \times 4 \text{ in.}^2}{1 \text{ in.}^2} \quad \gg \quad ? \text{ cm}^2 = 25.80 \text{ cm}^2$$

$$4 \text{ in.}^2 = 25.80 \text{ cm}^2$$

3. When cutting glass, the cutter should be 0.06 inches from the edge of the glass. How many millimetres is that?

Step 1: Convert imperial to metric

(1 in. = 25.4 mm)

$$\frac{? \text{ mm}}{0.06 \text{ in.}} = \frac{25.4 \text{ mm}}{1 \text{ in.}} \quad \gg \quad ? \text{ mm} = \frac{25.4 \text{ mm} \times 0.06 \text{ in.}}{1 \text{ in.}} \quad \gg \quad ? \text{ mm} = 1.52 \text{ mm}$$

$$0.06 \text{ in.} = 1.52 \text{ mm}$$

4. Calculate the area, in square centimetres, of a piece of glass that measures 6 feet x 3 inches.

Step 1: Convert feet to inches

(1 ft = 12 in.) >> 6 x 12 in. = 72 in.

Step 2: Calculate square inches

$$72 \text{ in.} \times 3 \text{ in.} = 216 \text{ in.}^2$$

Step 3: Convert from imperial to metric

(1 in.² = 6.45 cm²)

$$\frac{? \text{ cm}^2}{216 \text{ in.}^2} = \frac{6.45 \text{ cm}^2}{1 \text{ in.}^2} \quad \gg \quad ? \text{ cm}^2 = \frac{6.45 \text{ cm}^2 \times 216 \text{ in.}^2}{1 \text{ in.}^2} \quad \gg \quad ? \text{ cm}^2 = 1,393.20 \text{ cm}^2$$

$$216 \text{ in.}^2 = 1,393.20 \text{ cm}^2$$

5. A project requires 3.5 metres of electrode wire. Calculate the length in millimetres, centimetres and inches.

(1 m = 1000 mm) > 3.5 m = 3500 mm

(1 m = 100 cm) > 3.5 m = 350 cm

Convert from metric to imperial

(1m = 39.37 in.)

$$\frac{? \text{ in.}}{3.5 \text{ m}} = \frac{39.37 \text{ in.}}{1 \text{ m}} \quad \gg \quad ? \text{ in.} = \frac{39.37 \text{ in.} \times 3.5 \text{ m}}{1 \text{ m}} \quad \gg \quad ? \text{ in.} = 137.80 \text{ in.}$$

3.5 m = 137.80 in.

6. An electrode wire stickout is 3/8 inch. Calculate the length in millimetres and centimetres

Step 1: Change the fraction 3/8 to a decimal.

3/8 in = 0.375 in.

Step 2: Change from imperial to metric to find millimetres.

(1 in. = 25.4 mm)

$$\frac{? \text{ mm}}{0.375 \text{ in.}} = \frac{25.4 \text{ mm}}{1 \text{ in.}} \quad \gg \quad ? \text{ mm} = \frac{25.4 \text{ mm} \times 0.375 \text{ in.}}{1 \text{ in.}} \quad \gg \quad ? \text{ mm} = 9.525 \text{ mm}$$

0.375 in. = 9.525 mm = 9.53 mm

Step 3: Convert from imperial to metric to find centimeters.

(1 in. = 2.54 cm)

$$\frac{? \text{ cm}}{0.375 \text{ in.}} = \frac{2.54 \text{ cm}}{1 \text{ in.}} \quad \gg \quad ? \text{ cm} = \frac{2.54 \text{ cm} \times 0.375 \text{ in.}}{1 \text{ in.}} \quad \gg \quad ? \text{ cm} = 0.9525 \text{ cm}$$

0.375 in. = 0.9525 cm = 0.95 cm

7. Convert the following quantities to the metric measurements provided.

a) 2 lbs. of flux	0.91 kg (1 kg = 2.2 lb.)
b) 4 quarts (US) of solution	3.77 L (1 L = 1.06 qt. (US))
c) 3/4 in. pipe	1.19 cm (1 in. = 2.54 cm)
d) 100 lbs. of fire brick	45.45 kg (1 kg = 2.2 lb.)
e) 18 in. welding rod	45.72 cm (1 in. = 2.54 cm)

ANSWER KEY: Patio Layout

Skill Builders: Pythagorean Theorem, Volume, Calculating Area, Rounding

1. A client wants a garden installed in one corner of her new patio. The corner is a right angle. One of the sides along the edge of the garden is to be 2 m and the other side along the edge of the garden is to be 1.5 m. How long will the third side of the garden be?

$$(a^2 + b^2 = c^2)$$

$$1.5^2 + 2^2 = c^2$$

$$c^2 = 6.25$$

$$c = \sqrt{6.25}$$

$$c = 2.5 \text{ m}$$

2. The client would like the garden framed with landscaping timbers. What is the total length of timbers that needs to be purchased?

Sides $1.5 + 2 + 2.5 = 6 \text{ m}$

Total length = 6 m

3. The timbers are sold in 8 ft. lengths. How many lengths will need to be purchased to frame the garden?

Convert meters to feet.

Use conversion ratio (1 m = 3.28 ft.)

$$\frac{? \text{ ft.}}{6 \text{ m}} = \frac{3.28 \text{ ft.}}{1 \text{ m}} \quad \gg \quad ? \text{ ft.} = \frac{3.28 \text{ ft.} \times 6 \text{ m}}{1 \text{ m}} \quad \gg \quad ? \text{ ft.} = 19.68 \text{ ft.}$$

6 m = 19.68 ft.

Need to purchase three (3) lengths of 8 ft. timbers.

4. Steer manure needs to be ordered to fill the garden from the ground level to the top of the timbers. Manure is ordered in cubic metres. Assume the timbers are 4 x 4 inches and the manure needs to be level with the top of the timbers. How many cubic metres need to be ordered? *Round to the nearest hundredth. Recall the concept for area, volume and the conversion ratio provided (1 m = 39.37 in.).*

Recall: Area of a triangle = B (base) x H (height) ÷ 2

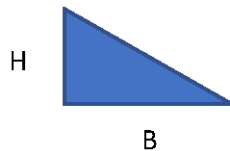

Recall: Volume of triangular prism = B (base) x L (length)

- where B = triangular area forming the base of a triangular prism;
- where L= the overall length (or height (H) or depth (D)) of the third dimension in the triangular prism.

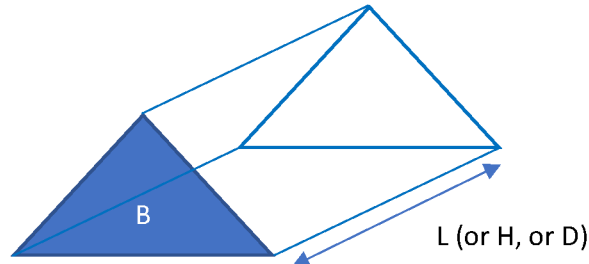

Calculate the quantity of steer manure needed.

Step 1: Convert the 4x4s to metres.

(1 m = 39.37 in.).

$$\frac{? m}{4 in.} = \frac{1 m}{39.37 in.} \quad \gg \quad ? m = \frac{1 m \times 4 in.}{39.37 in.} \quad \gg \quad ? m = 0.1016002 m$$

Step 2: Calculate volume of the triangular garden

$$V = B \times D$$

$$V = [B = \text{Area of triangle}] \times [D = \text{Depth of Timbers}]$$

$$V = [B = \text{Area of triangle} = \text{base} \times \text{height} \div 2] \times [\text{Depth of timbers} = 4 in. = 0.1016002 m]$$

$$V = [1.5 m \times 2 m \div 2] \times [0.1016002 m]$$

$$V = 0.1524003 m^3$$

Step 3: Round to the nearest hundredth.

$$V = 0.1524003 m^3$$

$$V = 0.15 m^3$$

5. Assume the patio is a rectangle and the shortest side of the garden is $\frac{1}{6}$ of the width of the finished patio. The longest side of the patio is 1.5 times the length of the shortest side. Using the graph paper on the next page, draw and label the patio including the new garden. Include information on the scale you use.

Shortest side of garden = 1.5 m

Width of patio $\div 6 =$ shortest side of garden

Width of patio = shortest side of garden $\times 6$

Width of patio = $1.5 \text{ m} \times 6 = 9 \text{ m}$

Width of patio = 9 m

Length of patio = $1.5 \times$ shortest side of patio (patio width)

Length of patio = $1.5 \times 9 \text{ m}$

Length of patio = 13.5 m

Patio dimensions (W X L) = 9 m x 13.5 m

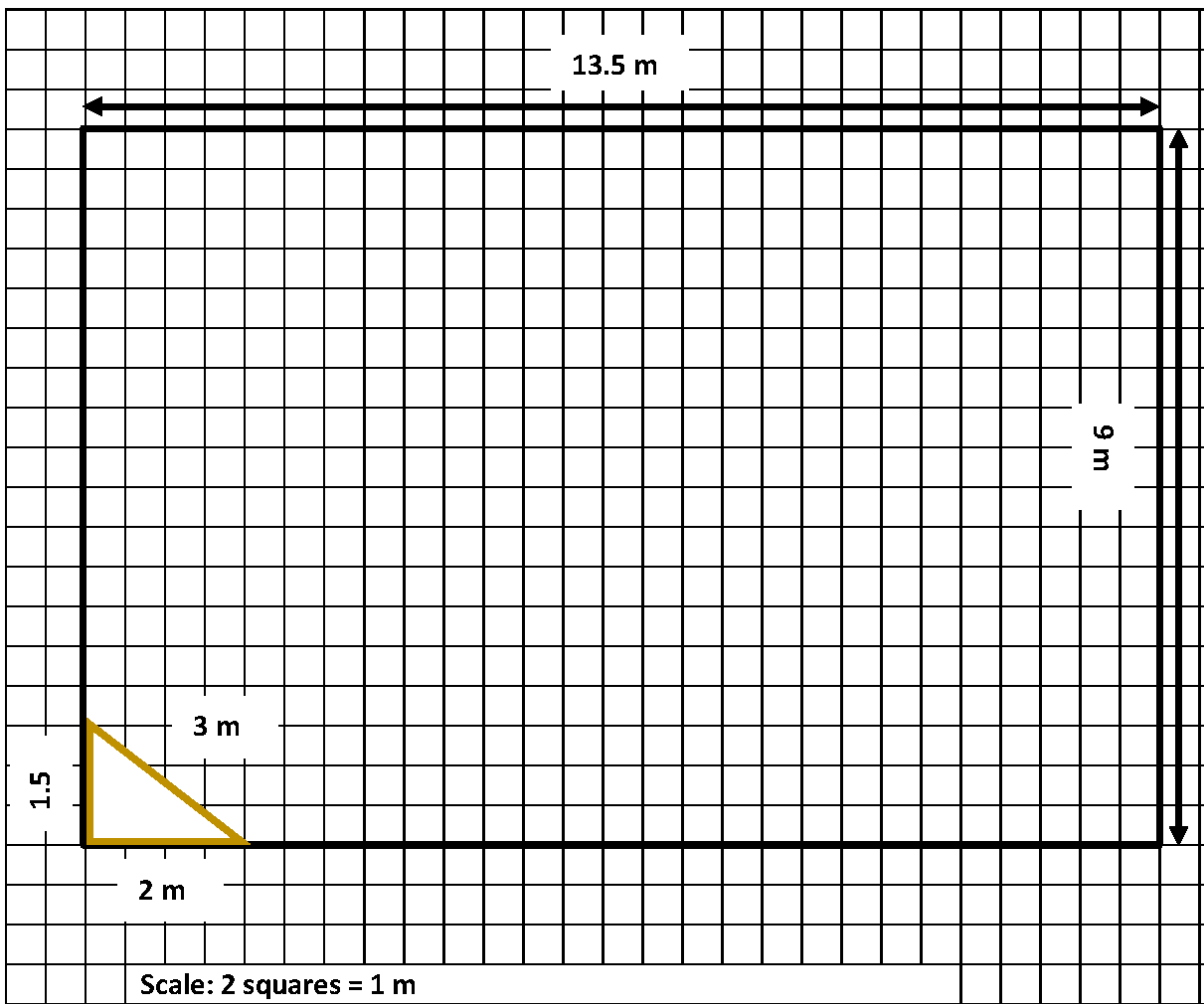

ANSWER KEY: Pay Statements
 Skill Builders: Key Words & Phrases, Entry Forms, Percentages, Decimals & Fractions

1. Refer to **Pay Statements 1** and **2** to complete the following table.

	Pay Statement 1	Pay Statement 2
Worker name	John Smith	Joseph Mayer
Cheque number	321654	0044853
Pay period end date	2013/11/25	2018/11/25
Pay date	2013/11/20	2018/12/03
Total hours worked	85	75
Gross pay	\$1,725.00	\$1200.00
Net pay	\$1,294.66	\$968.09
Year to date gross	\$39,675.00	\$30,000.00
Current EI deduction	\$28.62	\$22.56
Year to date CPP deduction	\$1,495.69	\$1,318.50

2. What do CPP, EI and YTD stand for? **Canada Pension Plan, Employment Insurance, and Year to Date**
3. What type of employee ID does each company use? **Pay statement 1 uses company issued ID numbers. Pay Statement 2 uses company issued employee numbers.**
4. Calculate the CPP and EI rates on Pay Statement 1.

$$65.03/1725 = 0.0376985$$

$$0.0376985 \times 100 = 3.76985$$

$$\text{CPP} = 3.77\%$$

$$28.62/1725 = 0.0165913$$

$$0.0165913 \times 100 = 1.65913$$

$$\text{EI} = 1.66\%$$

- If the rate of deduction for CPP goes up 1%, calculate the new deduction amounts for each employee for this pay period.

Pay Statement 1

Original CPP is 3.77%. Increase = 4.77%.

New CPP = $1725 \times 0.0477 = 82.2825$

New CPP = \$82.28

Pay Statement 2

Original CPP is 4.40%. Increase = 5.40%.

New CPP = $1200 \times 0.0540 = 64.80$

New CPP = \$64.80

- Calculate the total percentage of the deductions for this pay period for each employee.

Pay Statement 1

$430.34/1725 = 0.2494724$

$0.2494724 \times 100 = 24.94724$

= 24.95%

Pay Statement 2

$231.91/1200 = 0.1932583$

$0.1932583 \times 100 = 19.32583$

= 19.33%

ANSWER KEY: Product Installation

Skill Builders: Conversion, Technical Drawings, Rounding & Percentages, Decimals & Fractions

1. Answers shown in the technical drawings below.

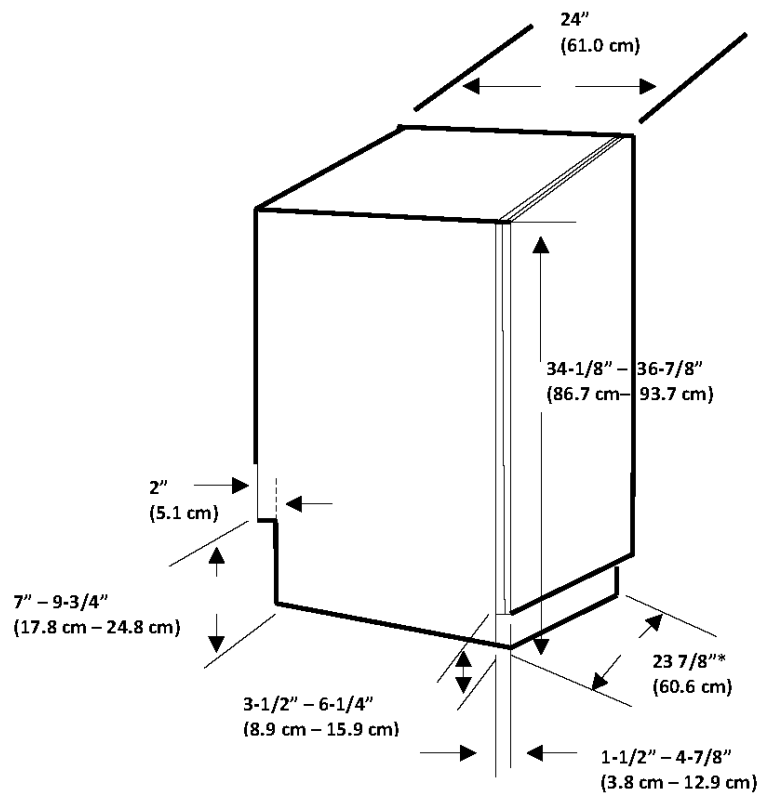
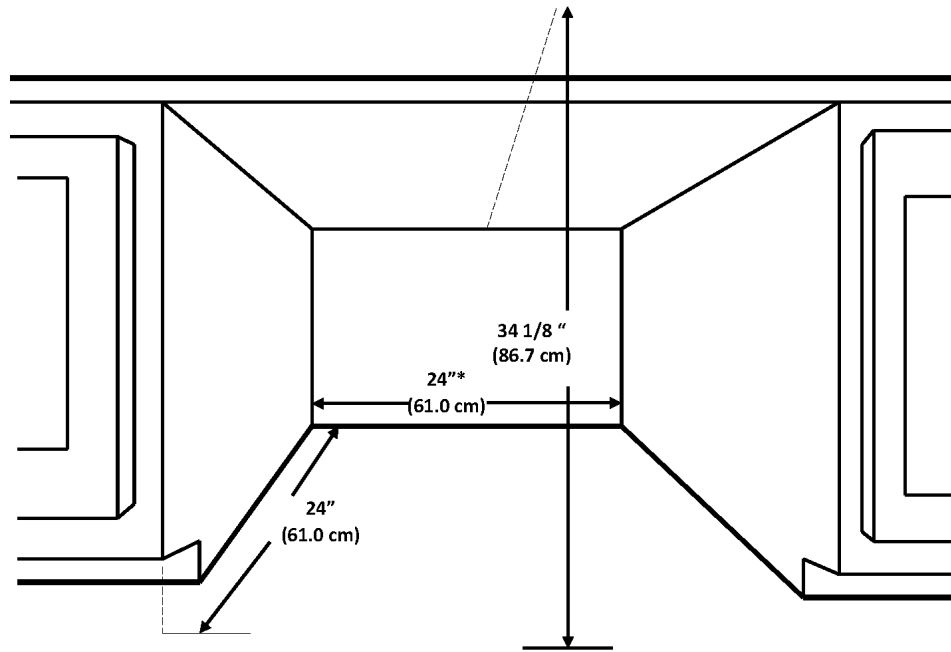

1. The technical drawings include both metric and imperial measurements. Calculate the correct conversion to centimetres for the four measurements that are circled and lettered on the drawing. Round to the nearest tenth. (1 inch = 2.54 cm)

A. $34\text{-}1/8'' = 86.7\text{ cm}$

$$\frac{? \text{ cm}}{34.125 \text{ in.}} = \frac{2.54 \text{ cm}}{1 \text{ in.}} \quad \gg \quad ? \text{ cm} = \frac{2.54 \text{ cm} \times 34.125 \text{ in.}}{1 \text{ in.}} \quad \gg \quad ? \text{ cm} = 86.\underline{6}775 \text{ in.}$$

B. $2'' = 5.1\text{ cm}$

$$\frac{? \text{ cm}}{2 \text{ in.}} = \frac{2.54 \text{ cm}}{1 \text{ in.}} \quad \gg \quad ? \text{ cm} = \frac{2.54 \text{ cm} \times 2 \text{ in.}}{1 \text{ in.}} \quad \gg \quad ? \text{ cm} = 5.\underline{0}8 \text{ in.}$$

C. $3\text{-}1/2'' - 6\text{-}1/4'' = 8.9\text{ cm} - 15.9\text{ cm}$

$$\frac{? \text{ cm}}{3.5 \text{ in.}} = \frac{2.54 \text{ cm}}{1 \text{ in.}} \quad \gg \quad ? \text{ cm} = \frac{2.54 \text{ cm} \times 3.5 \text{ in.}}{1 \text{ in.}} \quad \gg \quad ? \text{ cm} = 8.\underline{9}9 \text{ in.}$$

$$\frac{? \text{ cm}}{6.25 \text{ in.}} = \frac{2.54 \text{ cm}}{1 \text{ in.}} \quad \gg \quad ? \text{ cm} = \frac{2.54 \text{ cm} \times 6.25 \text{ in.}}{1 \text{ in.}} \quad \gg \quad ? \text{ cm} = 15.\underline{8}75 \text{ in.}$$

D. $1\text{-}1/2'' - 4\text{-}7/8'' = 3.8\text{ cm} - 12.4\text{ cm}$

$$\frac{? \text{ cm}}{1.5 \text{ in.}} = \frac{2.54 \text{ cm}}{1 \text{ in.}} \quad \gg \quad ? \text{ cm} = \frac{2.54 \text{ cm} \times 1.5 \text{ in.}}{1 \text{ in.}} \quad \gg \quad ? \text{ cm} = 3.\underline{8}1 \text{ in.}$$

$$\frac{? \text{ cm}}{4.875 \text{ in.}} = \frac{2.54 \text{ cm}}{1 \text{ in.}} \quad \gg \quad ? \text{ cm} = \frac{2.54 \text{ cm} \times 4.875 \text{ in.}}{1 \text{ in.}} \quad \gg \quad ? \text{ cm} = 12.\underline{3}825 \text{ in.}$$

2. If the dishwasher requires a half inch clearance on all 3 sides, and a half inch at the top, what are the dimensions of the largest dishwasher that will fit in the opening? Include width, depth, and height. Show your answers in imperial and metric.

$23\text{-}1/2\text{ in. (w)} \times 23\text{-}1/2\text{ in. (d)} \times 33\text{-}5/8\text{ in. (h)}$

$59.69\text{ cm (w)} \times 59.69\text{ cm (d)} \times 85.41\text{ cm (h)}$

3. Calculate the cubic volume of the opening, as shown in the Cutout Dimensions technical drawing. Show the dimensions in imperial.

$24\text{ in.} \times 24\text{ in.} \times 34.125\text{ in.} = 19,656\text{ in.}^3$

4. Trim pieces are provided with the unit to fit the opening shown in the drawing. Without side trims, the unit width and depth is 59.7 cm. Without top trim, the unit height is 85.7 cm.

Calculate the difference in volume between the unit with trim and without trim. Show your answer in imperial units. Round volume to the nearest whole number. (1 in.³ = 16.39 cm³).

Step 1: Calculate unit volume without trim.

$59.7\text{ cm.} \times 59.7\text{ cm.} \times 85.7\text{ cm.} = 305,442.51\text{ cm}^3$

Step 2: Convert unit volume from metric to imperial.

$$\frac{? \text{ in.}^3}{305,442.51 \text{ cm}^3} = \frac{1 \text{ in.}^3}{16.39 \text{ cm}^3} \quad \gg \quad ? \text{ in.}^3 = \frac{1 \text{ in.}^3 \times 305,442.51 \text{ cm}^3}{16.39 \text{ cm}^3} \quad \gg \quad ? \text{ in.}^3 = 18,635.91 \text{ in.}^3 = 18,636 \text{ in.}^3$$

$305,442.51\text{ cm}^3 = 18,636\text{ in.}^3$

Step 3: Subtract volume without trim from volume with trim.

$19,656\text{ in.}^3 - 18,636\text{ in.}^3 = 1,020\text{ in.}^3$

ANSWER KEY: Rough Openings: Calculation
Skill Builder: Tables & Lists, Technical Drawings

- Locate the following:
 - Frame width for a 5' door. **62"**
 - Opening height for the tallest 2'10" outswing door. **85 1/4"**
 - Minimum rough opening width for the smallest double door available. **58 1/2"**
 - Maximum opening height for 5' 8" door. **86"**
- Calculate the following:
 - 80" in feet. **6.67' or 6'8"**
 - 63 1/4" in feet: **5.27' or 5' 3 1/4"**
 - 84 1/2" in feet: **7.04' or 7' 1/2"**
- The rough opening was made for a 2'8" single door and should have been for a 4'8" double. Using the minimum rough opening dimensions for both, how much larger does the opening need to be? **24.5" or 24 1/2"**
- What is the difference between the largest opening height for a 2'6" inswing door and a 5'4" double outswing door? **3/4"**
- Label the illustration showing the rough opening measurement for the smallest double door shown in the chart. **Label should be 58-1/2"**.
- Label the illustration showing the shortest rough opening height measurement for a 6' o" double outswing door. **Label should be 81 1/4"**
- Refer to your textbook, or search online, to locate the rough opening width and height for a common window and door size. Label the illustration with those dimensions. **Answers will vary.**

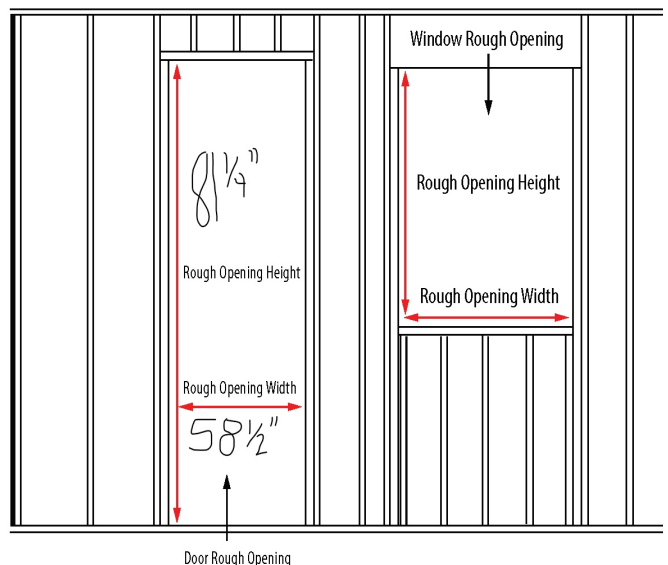

ANSWER KEY: Rough Openings: Conversion Skill Builders: Conversion, Rounding, Tables & Lists

1. Convert the following from inches to mm. Calculate to 2 decimal places. Include the unit in your answer. (1 in. = 25.4 mm)

a) $27\frac{3}{4}$ " **704.85 mm**

$$\frac{? \text{ mm}}{27.75 \text{ in.}} = \frac{25.4 \text{ mm}}{1 \text{ in.}} \quad \gg \quad ? \text{ mm} = \frac{25.4 \text{ mm} \times 27.75 \text{ in.}}{1 \text{ in.}} \quad \gg \quad ? \text{ mm} = 704.85 \text{ mm}$$

b) 84" **2133.60 mm**

$$\frac{? \text{ mm}}{84 \text{ in.}} = \frac{25.4 \text{ mm}}{1 \text{ in.}} \quad \gg \quad ? \text{ mm} = \frac{25.4 \text{ mm} \times 84 \text{ in.}}{1 \text{ in.}} \quad \gg \quad ? \text{ mm} = 2133.60 \text{ mm}$$

c) $71\frac{1}{4}$ " **1809.75 mm**

$$\frac{? \text{ mm}}{71.25 \text{ in.}} = \frac{25.4 \text{ mm}}{1 \text{ in.}} \quad \gg \quad ? \text{ mm} = \frac{25.4 \text{ mm} \times 71.25 \text{ in.}}{1 \text{ in.}} \quad \gg \quad ? \text{ mm} = 1809.75 \text{ mm}$$

2. Convert the following from mm to inches. Calculate to the closest 1/8 inch. Include the unit in your answer. (1 in. = 25.4 mm)

a) 2032 mm **80"**

$$\frac{? \text{ in.}}{2032 \text{ mm}} = \frac{1 \text{ in.}}{25.4 \text{ mm}} \quad \gg \quad ? \text{ in.} = \frac{1 \text{ in.} \times 2032 \text{ mm}}{25.4 \text{ mm}} \quad \gg \quad ? \text{ in.} = 80 \text{ in.}$$

b) 915 mm **36"**

$$\frac{? \text{ in.}}{915 \text{ mm}} = \frac{1 \text{ in.}}{25.4 \text{ mm}} \quad \gg \quad ? \text{ in.} = \frac{1 \text{ in.} \times 915 \text{ mm}}{25.4 \text{ mm}} \quad \gg \quad ? \text{ in.} = 36.02 \text{ in.}$$

c) 1000 mm **39-3/8"**

$$\frac{? \text{ in.}}{1000 \text{ mm}} = \frac{1 \text{ in.}}{25.4 \text{ mm}} \quad \gg \quad ? \text{ in.} = \frac{1 \text{ in.} \times 1000 \text{ mm}}{25.4 \text{ mm}} \quad \gg \quad ? \text{ in.} = 39.37 \text{ in.}$$

3. Complete the following table of popular door sizes. Include the unit in your answers. Calculate all metric measurements to the nearest whole number.

Metric mm	Imperial feet & inches	Imperial inches
1830 mm x 610 mm	6' 0" x 2' 0"	72" x 24"
1981 mm x 457 mm	6' 6" x 1' 6"	78" x 18"
1981 mm x 762 mm	6' 6" x 2' 6"	78" x 30"
2038 mm x 613 mm	6' 8-1/4" x 2'-1/8"	80-1/4" x 24-1/8"
2040 mm x 721 mm	6' 8-5/16" x 2' 4-3/8"	80-5/16" x 28-3/8"

4. Recreate the Opening Height sub-headings and the first 2 lines of the **Rough Openings** table using metric instead of imperial measurements. Calculate to the nearest whole number. Include the unit in your answers.

Rough Openings

Door Description	Opening Width		Opening Height	
	Actual Frame Width Size	Stud to Stud Rough Opening Minimum	2032 mm	2134 mm
610 mm	648 mm	661 mm	Inswing 2083 mm	Inswing 2184 mm
711 mm	749 mm	762 mm	Outswing 2064 mm	Outswing 2165 mm

ANSWER KEY: Tiny House
Skill Builder: Calculating Area, Technical Drawings

1. Is the structure intended to be fixed in place or movable? How do you know? **Movable. There is a trailer hitch.**
2. How many stories is the structure? **1 ½ (1 + a loft and bedroom on the second level with an open ceiling above the LR).**
3. What is the exterior perimeter of the structure? **80 ft. 8 in.**
4. What is the total square footage of the bedroom (including the closet)?
(5 ft. 8 in. x 12 ft.) + (2 ft. 6 in. x 8 ft. 2 in.)
 $(5.67 \text{ ft.} \times 12 \text{ ft.}) + (2.5 \text{ ft.} \times 8.17 \text{ ft.}) = 68 \text{ ft.}^2 + 20.4167 \text{ ft.}^2 = 88.42 \text{ ft.}^2$
5. What are the dimensions of the staircase? **2 ft. 6 in. x 3 ft. 4 in.**
6. How many exits are there? Where are they? **Two. 1 at the end opposite the hitch and 1 to the left of the kitchen.**
7. What is the total square footage of the developed spaces on the second level?
(answer from 4) + (8 ft. 4 in. x 5 ft.)
 $88.42 \text{ ft.}^2 + (8.33 \text{ ft.} \times 5) = 130.08 \text{ ft.}^2$
8. What is the square footage of the kitchen?
8 ft. 4 in. x 8 ft. 8 in.
 $8.33 \text{ ft.} \times 8.67 \text{ ft.} = 72.22 \text{ ft.}^2$
9. What are the dimensions of the bathroom? **3 ft. x 8 ft. 4 in.**
10. If a city bylaw permits tiny houses that occupy no more than ½ of the existing backyard, how large must the yard be to accommodate this structure? **The backyard must be equal to or greater than 16 ft. 8 in. x 32 ft. OR, 8 ft. 4 in. x 64 ft.**

OR

The backyard dimensions must have an area of at least 533.12 sq. ft. (the square footage of the main level of the house x 2).

8 ft. 4 in. x 32 ft.

$8.33 \text{ ft.} \times 32 \text{ ft.} = 266.56 \text{ ft.}^2$

$266.56 \text{ ft.}^2 \times 2 = 533.12 \text{ ft.}^2$

ANSWER KEY: Volume of Cylinders and Cones

Skill Builders: Volume, Rounding

1. A cylindrical septic tank is 1.2m in diameter and 1.8m high. How many litres will it hold? Round to the nearest whole number. (1 m³ = 1000 L)

$$V = \pi r^2 h$$

$$V = \pi \times 0.6^2 \times 1.8$$

$$V = 2.036 \text{ m}^3$$

$$V = 2.036 \times 1000$$

$$V = 2036 \text{ litres}$$

2. A rainwater downpipe is 30" high and 4" wide. Calculate the volume of the pipe, in litres. Round to the nearest hundredth. (1 L = 61.023 in.³)

$$V = \pi r^2 h$$

$$V = \pi \times 2^2 \times 30 \text{ in.}$$

$$V = 376.991 \text{ in.}^3$$

$$V = \frac{? \text{ L}}{376.991 \text{ in.}^3} = \frac{1 \text{ L}}{61.023 \text{ in.}^3} \gg V = \frac{1 \text{ L} \times 376.991 \text{ in.}^3}{61.023 \text{ in.}^3} \gg V = 6.178 \text{ L}$$

$$V = 6.18 \text{ litres}$$

3. Residential sewer pipe, connected to a toilet, must have a diameter that is a minimum of 3". Using that standard, if the pipe is 20' long, calculate the volume of the pipe, in litres. Round to the nearest tenth. (1 L = 61.023 in.³).

Converted all measurements to inches. >> 20 ft. = 240 in.

$$V = \pi r^2 h$$

$$V = \pi \times 1.5^2 \times 240 \text{ in.} = 1696.46 \text{ in.}^3$$

$$V = \frac{? \text{ L}}{1696.46 \text{ in.}^3} = \frac{1 \text{ L}}{61.023 \text{ in.}^3} \gg V = \frac{1 \text{ L} \times 1696.46 \text{ in.}^3}{61.023 \text{ in.}^3} \gg V = 27.800 \text{ L}$$

$$V = 27.8 \text{ litres}$$

4. A storage tank is 13' in diameter and 3m high. How many gallons will it hold? There are 7.481 cubic feet in a US liquid gallon. Round to the nearest hundredth. (1 gal. (US) = 7.48 ft.³ and (1 m = 3.28 ft.)

Converted all measurements to feet. >> 3m = 9.48 ft.

$$V = \pi r^2 h$$

$$V = \pi \times 6.5^2 \times 9.48 \text{ ft.}$$

$$V = 1306.08573 \text{ ft.}^3$$

$$V = \frac{? \text{ gal. (US)}}{1306.08573 \text{ ft.}^3} = \frac{1 \text{ gal. (US)}}{7.48 \text{ ft.}^3} \gg V = \frac{1 \text{ gal. (US)} \times 1306.08573 \text{ ft.}^3}{7.48 \text{ ft.}^3} \gg V = 9770.827345 \text{ gal. (US)}$$

$$V = 9770.83 \text{ gallons (US)}$$

5. A storm water pipe has an exterior dimension of 8" and the interior dimension is 1" smaller. Calculate the volume, of the pipe, in litres, per 50'. Round to the nearest hundredth. (1 L = 61.023 in.³)

Converted all measurements to inches. >> 50 ft. = 600 in.

$$V = \pi r^2 h$$

$$V = \pi \times 3.5^2 \times 600 \text{ in.}$$

$$V = 23,090.706 \text{ in.}^3$$

$$V = \frac{? L}{23,090.706 \text{ in.}^3} = \frac{1 L}{61.023 \text{ in.}^3} \gg V = \frac{1 L \times 23,090.706 \text{ in.}^3}{61.023 \text{ in.}^3} \gg V = 378.393 L$$

V = 378.39 litres (per 50 ft.)

6. Once it is welded, the bottom cone for a grain hopper will have a height of 2.04 metres and the radius will be 1.57 metres. How much grain will the cone hold? Round to the nearest hundredth.

$$V = \pi r^2 h \div 3$$

$$V = \pi \times 1.57^2 \times 2.04 \div 3$$

$$V = 15.79717193 \text{ m}^3 \div 3$$

$$V = 5.265723978 \text{ m}^3$$

$$V = 5.27 \text{ m}^3$$

7. By looking at the amount of fill dropped off at a construction site, the foreperson estimates that it is not going to be enough for the area that needs to be filled. The fill is piled in a cone shape on the edge of the site. The amount ordered was 100 m³. The pile of fill is 7.5 m high with a diameter of 7 m. Was enough fill delivered? Show your calculations. Round to the nearest tenth.

$$V = \pi r^2 h \div 3$$

$$V = \pi \times 3.5^2 \times 7.5 \div 3$$

$$V = 288.633825 \text{ m}^3 \div 3$$

$$V = 96.21127502 \text{ m}^3$$

$$V = 96.2 \text{ m}^3$$

No. The amount of fill delivered is about 4 cubic metres short.

8. Engine cleaner needs to diluted at 180 mL of liquid concentrate in 4 litres of water. Is the bucket below large enough to hold the mixture? Round to the nearest hundredth. (1 mL = 1000 m³) and (1 L = 1000 mL)

Calculate volume in mm³

$$V = \pi r^2 h$$

$$V = \pi \times 100^2 \times 140 \text{ mm}^3$$

$$V = 4,398,229.715 \text{ mm}^3$$

$$V = \frac{? \text{ mL}}{4,398,229.715 \text{ m}^3} = \frac{1 \text{ mL}}{1000 \text{ m}^3} \gg V = \frac{1 \text{ mL} \times 4,398,229.715 \text{ m}^3}{1000 \text{ m}^3} \gg V = 4,398.229715 \text{ mL}$$

$$V = \frac{? L}{4,398.229715 \text{ mL}} = \frac{1 L}{1000 \text{ mL}} \gg V = \frac{1 L \times 4,398.229715 \text{ mL}}{1000 \text{ mL}} \gg V = 4.398229715 L$$

$$V = 4.40 L$$

Yes. The bucket can hold almost 4.4 litres and the concentrate and water mixed together are only 4.18 litres.

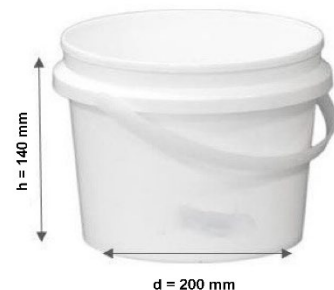

ANSWER KEY: Work Schedules

Skill Builders: Key Words & Phrases, Tables & Lists

1. How many days a week does the company operate? **6 days.**
2. Which crew has the fewest working days this period? **Crew C (9 days)**
3. Crew B needs to add a day on Monday the 21. Which crew is available to assist? **Crew C.**
4. Which project are scheduled for the shortest period of time? **Main St. and Teal Trail are both scheduled for only 1 day.**
5. Kim is unable to work on the final day of the 42nd Avenue project. What workers could be available to pick up the shift? **Anyone from Crew A.**
6. Which crew will be working at the Paper Street site on the June 25? **Crew B.**
7. Which crew works the fewest number of job sites this period? **Crew B (2 sites. Treesdale and Paper).**
8. On which day will work at 659 Treesdale Crt be completed? **Saturday June 19.**
9. Which crew does not work Saturdays? **Crew A.**
10. Each shift is 8.5 hours. How many hours will Hester work during this pay period? **76.5 hours.**